

# Electrode Steam Humidifier

## HyLine



## A Word about Water Quality

The mode of operation of all electrode steam humidifiers is based on the fact that water contains minerals and is therefore conductive.

- "normal" tap water is ideal.
- but what is "normal" tap water exactly?

Users of HygroMatik units in the most diverse areas consider their tap water "normal."

HygroMatik typically defines "normal" as feed water with a conductivity between 200 and 500  $\mu\text{S}/\text{cm}$  (microSiemens per centimeter) at 15° C.

Some areas, however, are supplied with tap water whose quality is outside the parameters specified by HygroMatik. If the HygroMatik steam humidifier's control is not adjusted correctly in these areas, the unit cannot perform optimally. For example, the electrodes could wear out particularly quickly or the steam production could be too low.

The operational parameters set by HygroMatik in the factory are intended for normal tap water. However, they can very easily be reprogrammed to fit the special requirements of a particular area. In addition, it is possible to install a plastic star in the cylinder in order to increase the life span of the electrodes or to provide a flushing mechanism to extend maintenance intervals.

Because of this you should monitor your new unit during initial operation. Make sure that it has been properly installed and is operating to your satisfaction.

Consult your HygroMatik specialists. We will test the quality of your water and advise you on installation and initial operation. Your HygroMatik steam humidifier will be carefully adapted to your particular application.

© Copyright HygroMatik GmbH; HyLine, September 2011

Information in this manual is subject to change or alteration without prior notice.

Current version of this manual can be found at: [www.hygromatik.co.uk](http://www.hygromatik.co.uk)



**Warning, Hazardous Voltage:** All work to be performed by trained personnel only. All electrical installation and servicing of the electrical components of this unit to be performed by qualified electricians only. Disconnect power supply before installation and servicing!

<b>1. Introduction</b> .....	<b>5</b>
1.1 Directions for Use .....	5
1.2 Typographic Distinctions .....	6
1.3 Documentation .....	7
<b>2. Safety Notes</b> .....	<b>8</b>
2.1 Overview .....	8
2.2 Guidelines for Safe Operation .....	8
2.3 Disposal after Dismantling .....	9
<b>3. Transport</b> .....	<b>10</b>
3.1 Overview .....	10
3.2 Carton outer Size and Weight .....	10
3.3 Packing .....	11
3.4 Interim Storage .....	11
3.5 Check for Complete and Correct Delivery of Goods .....	11
3.6 Included in the Delivery .....	11
<b>4. Operation and Installation</b> .....	<b>12</b>
4.1 Mode of Operation .....	12
4.2 Installation and Operation .....	12
<b>5. Installation</b> .....	<b>15</b>
5.1 Steam Humidifier Operating Environment .....	15
5.1.1 Fitting measures .....	16
5.1.2 Unit Dimensions HY05-HY45 .....	18
5.1.3 Unit Dimensions HY60-HY116 .....	19
5.2 Fan Unit (optional) .....	20
5.2.1 Fan Unit Type VG .....	20
5.2.2 Fan Unit Cover .....	21
5.3 Absorption Distance BN .....	22
5.3.1 Determining the Absorption Distance .....	22
5.3.2 Absorption Distance Nomogram .....	24
5.4 Steam Manifold .....	25
5.4.1 Notes on Installation .....	25
5.5 Steam Line .....	29
5.6 Cover Plate .....	30
5.7 Drill Pattern .....	31
5.8 Condensate Hose .....	33
5.9 Types of Installation .....	33
5.10 Steam Solenoid Valves .....	35
5.11 Unit Installation Check .....	35
<b>6. Water Installation</b> .....	<b>36</b>
6.1 Operation with Softened Water .....	36
6.2 Water Supply .....	37
6.3 Water discharge .....	38
6.4 Water Installation Check .....	39

---

<b>7. Electrical Connection .....</b>	<b>40</b>
7.1 Electrical Installation .....	40
7.2 Cable Connections .....	42
7.3 Fan Unit .....	43
7.4 Safety Interlock .....	44
7.5 Wiring Diagram .....	44
7.6 Electrical Installation Checklist .....	44
<b>8. Commissioning .....</b>	<b>45</b>
<b>9. Maintenance .....</b>	<b>46</b>
9.1 Maintenance Work .....	46
9.2 Access Electrical Enclosure .....	47
9.3 Removing and Cleaning the Steam Cylinder .....	48
9.4 Electrode wear .....	53
9.4.1 Original Electrode Lengths .....	54
9.4.2 Uneven Electrode Lengths .....	54
9.5 Replacing Electrodes .....	54
9.6 Cleaning the Blow- Down Pump .....	56
9.7 Cleaning the Water Inlet Solenoid Valve .....	57
9.8 Checking Cable Connections and Electrode Cables .....	57
9.9 Checking Hoses .....	58
9.10 Checking Operation .....	58
9.11 Dismantling .....	58
<b>10. EC-Declaration of Conformity .....</b>	<b>59</b>
<b>11. Spare Parts .....</b>	<b>60</b>
<b>12. Fax Form - Order for spare parts .....</b>	<b>65</b>
<b>13. Technical Specification .....</b>	<b>66</b>
<b>14. Exploded View .....</b>	<b>68</b>
<b>15. View of housing .....</b>	<b>69</b>

## 1. Introduction

**Dear Customer,**

Thank you for choosing a steam humidifier.

HygroMatik steam humidifiers represent the latest in humidification technology.

They will impress you with their safety, ease of use and economical operation.

In order to operate your HygroMatik steam humidifier safely, properly and efficiently, please read these operating instructions.

Employ your steam humidifier only in sound condition and as directed. Consider potential hazards and safety issues and follow all the recommendations in these instructions.

If you have additional questions, please contact us:

**Tel.: +49-(0)4193 / 895-0 (Main Number)**

**Tel.: +49-(0)4193 / 895-293 (Technical Support Hotline)**

**Fax: +49-(0)4193 / 895-33**

**e-mail: hot1@HygroMatik.de**

For all technical questions or spare parts orders, please be prepared to provide unit type and serial number (see name plate on the unit).

### 1.1 Directions for Use

The HygroMatik steam humidifier is intended for steam production.

Proper usage also entails following HygroMatik's instructions for installation, dismantling, reassembly, initial operation and operation and maintenance, as well as disposal procedures.

Only qualified, authorized personnel may operate or service the unit. Workers who transport or service the unit must have read and understood the relevant sections of the operating instructions, especially the section "Safety Notes." In addition, staff must receive safety training about potential hazards from the operator. Place a copy of the operating instructions at the location where the unit is operated.

Use feed water with a conductivity between 125 and 1250  $\mu\text{S}/\text{cm}$  only

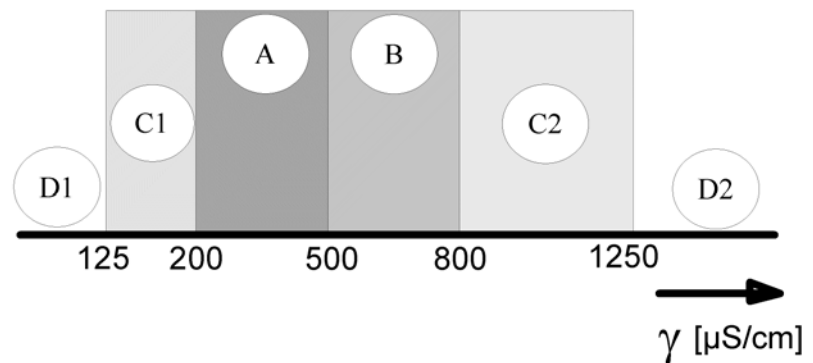

D1: Lower threshold

C1: Range of reduced conductivity (adjustments recommended)

A: Normal tap water

B: Range of heightened conductivity

C2: Range of high conductivity (adjustments recommended)

D2: Upper threshold



**Warning:** HygroMatik steam humidifiers emit steam with a temperature of 100° C. The steam may not be inhaled directly.

The HygroMatik Steam Humidifier is not designed for outdoor fitting

## 1.2 Typographic Distinctions

- preceded by a bullet: general specifications.
- » preceded by an arrow: Procedures for servicing or maintenance which should or must be performed in the indicated order.
- ☑ Installation step which must be checked off.
- italics* Terms used with graphics or drawings..

## **1.3 Documentation**

### **Retention**

Please retain these operating instructions in a secure, always accessible location. If the product is resold, turn the documentation over to the new operator. If the documentation is lost, please contact HygroMatik.

### **Versions in Other Languages**

These operating instructions are available in several languages. If interested, please contact HygroMatik or your HygroMatik dealer.

## 2. Safety Notes

### 2.1 Overview

These safety notes are required by law. They promote workplace safety and accident prevention.

#### Warnings and Safety Symbols

The safety symbols below identify sections containing warnings about hazards or potential dangers. Please familiarize yourself with these symbols.



**Warning:** Failure to observe this warning may result in serious injury or death and/or damage to the unit.



**Danger, Hazardous Voltage:** Hazardous electrical current! Failure to observe this warning may result in injury or even serious injury or death.



**Warning:** Failure to follow these instructions may result in damage to the unit due to electrostatic discharge. The electronic components of the humidifier control are very sensitive to electrostatic discharges. In order to safeguard these components during installation and servicing, steps must be taken to protect against ESD.



**Reminder:** Materials and consumables must be handled and/or disposed of as required by law.



**Note:** Appears before explanations or cross-references which refer to other sections of the operating instructions.

### 2.2 Guidelines for Safe Operation

#### Overview

Obey all safety notes and warnings present on the unit. In case of a malfunction, switch off the unit immediately and prevent a restart. Repair malfunctions promptly. After any repair work, have qualified personnel check the safe operation of the unit.

Use original spare parts only. Additional national safety regulations also fully apply to the operation of this unit.

This unit is not designed for the use by persons (also children) with limited physical, sensory and mental abilities - or without knowledge and experience. Unless they are supervised or trained by a person, who is responsible for their safety.

Supervise children in order to ensure that they will not play with the unit.

The unit is only allowed to work with connected steam hose that



safely leads the steam.

HygroMatik steam humidifiers are IP20-protected. Make sure that the unit is protected from drips in its installed location.

Installing a humidifier in a room without water discharge requires safety devices to protect against water leakages.

### Accident Prevention Regulations



Comply with the Accident Prevention Regulation Electrical Systems and Equipment to prevent injury to yourself and others.

### Operation of the Unit:

Do not perform any work which compromises the safety of the unit. Regularly check that all safety and monitoring devices are functioning normally. Do not remove or disable safety devices.

### Installation, Dismantling, Maintenance and Repair of the Unit:

Disconnect unit components from power supply prior to maintenance or repair work.

Attaching or installing **additional components** is permitted only with the **written consent** of the manufacturer.

### Electrical



Work on the electrical system must be performed by qualified personnel.

Disconnect unit components from power supply prior to work.

It is not allowed to connect the unit to DC voltage supply.

In case of a malfunction in the electrical power supply, switch off the unit immediately. Use only original fuses with the appropriate amperage rating. Regularly check the unit's electrical equipment. Promptly repair any damage, such as loose connections, burned wiring or defective electrical insulation. After proper electrical installation or repair, test all safety mechanisms (such as grounding resistance).

## 2.3 Disposal after Dismantling



**Note:** The operator is responsible for the disposal of unit components as required by law.

### 3. Transport

#### 3.1 Overview



**Note:** Proceed carefully when transporting the steam humidifier in order to prevent damage due to stress or careless loading and unloading.

#### 3.2 Carton outer Size and Weight

**HyLine:**

Type*	Height [cm]	Width [cm]	Depth [cm]	Weight [kg]
<b>HY05- 08</b>	58	56	32	16
<b>HY13- 17</b>	75	63	37	24
<b>HY23</b>	75	63	37	25
<b>HY30</b>	81	67	41	33
<b>HY45</b>	88	76	48	46
<b>HY60</b>	80	104	41	54
<b>HY90- 116</b>	90	117	48	77

**CompactLine:**

Type*	Height [cm]	Width [cm]	Depth [cm]	Weight [kg]
<b>C01</b>	46	45	26	11
<b>C02</b>	48	44	31	12
<b>C06</b>	52	50	28	13
<b>C10</b>	58	51	31	14
<b>C17</b>	75	54	37	22
<b>C22</b>	75	54	37	22
<b>C30</b>	75	58	37	23
<b>C45</b>	81	63	41	25
<b>C58</b>	90	72	48	36

**MiniSteam:**

Type*	Height [cm]	Width [cm]	Depth [cm]	Weight[kg]
<b>MS 5</b>	59	48	28	13
<b>MS 10</b>	68	51	31	15

\* Dimensions and weights may vary slightly.

### 3.3 Packing



**Note:** Notice the symbols affixed to the packing box.

### 3.4 Interim Storage

Store the unit in a dry place and protect from frost.

### 3.5 Check for Complete and Correct Delivery of Goods

Upon receipt of the unit, confirm that:

- the type and serial number on the name plate match those specified in the order and delivery documents and
- the equipment is complete and all parts are in perfect condition



**Note:** In case of damage during shipment or missing parts, immediately notify the carrier or supplier in writing.

Time limits for filing freight claims with shipping companies are\*:

Shipping Companies	After Receipt of Goods
Mail	no later than 24 hours
Rail	no later than 7 days
Truck and Rail Carriers	no later than 4 days
Parcel Service	immediately

\* Time limits for some services subject to change.

### 3.6 Included in the Delivery

The delivery includes:

- Unit of the selected humidifier type including selected control.
- Water installation hose 0,6m, 3/4".
- Mounting set with anchors and screws. For HyLine types HY45 to HY116, extra mounting bar.
- Operating Instructions for the unit and the control.
- Ordered accessories (steam manifold, steam hose, condensate hose, etc.).
- Maintenance o-ring set for steam cylinder.

---

## 4. Operation and Installation

### 4.1 Mode of Operation

The HygroMatik steam humidifier utilizes the conductivity normally present in tap water for steam production. Electrodes inside an enclosed steam cylinder are immersed directly into the tap water. They are connected to the alternating current.

The conductivity of the water generates an electric current between the electrodes. In this way, the electric power supplied is converted directly into heat without energy loss.

The amperage is a function of the available voltage, the immersed electrode surface area, the average distance between the electrodes and the water conductivity. The steam output of the humidifier is determined by electric power usage, which is regulated by increasing or decreasing the immersed surface area of the electrodes.

Concurrently, a self-regulating control keeps conductivity within a specified range.

The steam produced has a temperature of about 100°C with minimal excess pressure ("pressureless steam"). It is largely free of minerals and germ-free. Mineral deposits typically remain behind in the cylinder.

### 4.2 Installation and Operation

By pressing the control switch („Pos. I”) the humidifier is turned on. When the controller specifies an increase in humidity, the main contactor is switched on and the electrodes (48) are supplied with power. The water inlet solenoid valve (25) feeds water into the steam cylinder (16+19).

As soon as the electrodes are immersed, the current begins to flow. The water is now heated. When the pre-selected output is reached, the control turns off the solenoid valve and interrupts the water supply.

After a short heating up period, the water between the electrodes begins to boil and vaporize. The vaporization lowers the water level in the steam cylinder, reducing the output provided. The inlet solenoid valve, equipped with a fine mesh filter, intermittently admits fresh water.

Humidifier power usage is continuously monitored. With a cold start-up, the nominal current increases to 125% in order to achieve quick-start output parameters. This activates the electronic overflow limiter which causes a partial draining of the cylinder. This reduces the immersed surface area of the electrodes, lowering power usage.

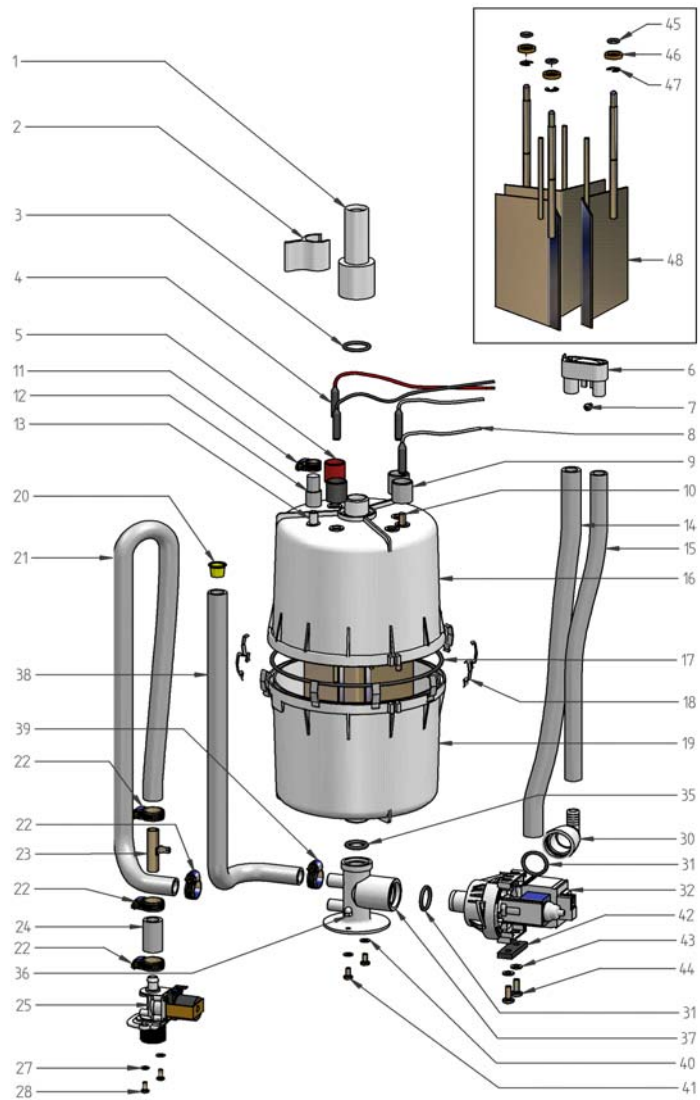

Please also see Section „Exploded View“.

Location	Designation
1	adapter
6	vent pipe
10	max. water level sensor electrode
14	water drain, discharge
16	top part of steam cylinder
17	o-ring cylinder flange
18	cylinder flange and o-ring
19	lower part of cylinder
25	solenoid valve water inlet
32	blow-down pump
35	o-ring
37	cylinder base
48	electrodes

---

The concentration of dissolved salts increases over time, which can lead to a rise in the conductivity of the water. If this continues, conductivity may increase until a short circuit occurs. This could damage the unit, but in any case would significantly reduce the life span of the electrodes.

For this reason, regular, periodic blow-downs of some of the concentrated water are very important. Following this procedure as recommended provides stable cylinder water conductivity as well as minimal water loss for the expected service life of the cylinder.

Water blow-down is performed by a blow-down pump (32). The functioning of the blow-down pump is continuously monitored during operation. If the pump is damaged, the steam humidifier shuts down.

With normal water quality, the blow-down loss rate is between 7% and 15% of the amount of steam produced. The steam cylinder requires complete drainage every 3-8 days, regardless of the water quality.

Mineral deposits settle in the open area below the electrodes and are removed through periodic maintenance. The blow-down pump itself has wide openings and can flush out smaller pieces of mineral deposit. This extends the service life of the unit and reduces the required maintenance interval.

During blow-downs, water flows from the pump into the drainage system.

A sensor electrode (10) monitors the maximum water capacity of the cylinder. When the water level reaches the sensor electrode, the water supply is interrupted. This can occur when the water has low conductivity or when the electrodes are worn out. In the case of low water conductivity, however, this state usually lasts only a short time. The built-in control and the large area electrodes combine to produce a rapid rise in conductivity by increasing the concentration of the water.

The steam cylinder consists of a top (16) and lower (19) part joined with a cylinder flange. The seal between the cylinder and cylinder base (37), as well as between the top and lower part of the cylinder, is maintained using an o-ring (35+17).

For maintenance the cylinder can be drained by pressing the control switch „Pos.II”.

## 5. Installation



**Warning:** Installation of this unit to be attempted only by qualified personnel. We accept no liability for damage due to faulty installation.

Obey all safety notes and warnings present on the unit.

During installation the unit must be disconnected from its power supply.

Attaching or installing additional components is permitted only with the written consent of the manufacturer, or else the warranty is void.



**Warning:** If the installation of this unit is attempted by only one person there is a risk that the unit drops down. We propose to carry out the installation by two persons.

### 5.1 Steam Humidifier Operating Environment



**Note:** When selecting the installation site for the steam humidifier, note that:

- Ambient temperature must be between +5° and +40° C. Relative humidity must not exceed 80% RH.
- An Installation in a closed room requires aeration and if necessary temperature conditioning in order to reach the above mentioned environmental conditions.
- The minimum clearances indicated in the diagram below must be observed; these are necessary to ensure adequate ventilation for the housing.
- HygroMatik humidifiers are not suitable for direct outdoor installation.
- The steam humidifier should be installed as close as possible to the steam manifold. Optimal performance is guaranteed only with short lengths of steam and condensate hose.
- Hoses must be laid at a consistent 5-10% incline to prevent sagging and kinking.
- The rear panel of the steam humidifier heats up during operation (to a maximum of 60°C). Take care that the construction on which the unit is mounted is not made of temperature-sensitive material.
- Place the steam humidifier so that the unit is easily accessible with sufficient space to perform maintenance.
- The steam humidifier is not qualified for exterior applications.

## 5.1.1 Fitting measures

### Clearances

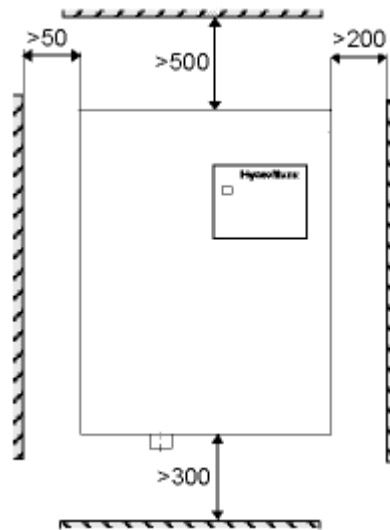

**Note:** When choosing the site for the steam humidifier, consider the location of existing water installations (feed and drain lines).

### Mounting Fixtures (for HY45 to HY116)

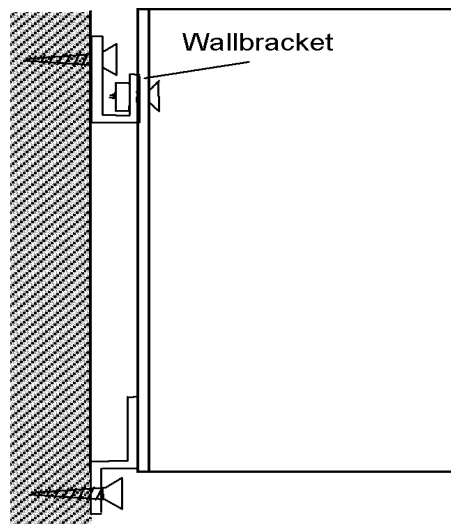

The unit should be mounted on a stable wall.



**Note:** To achieve a uniform immersed surface area for the electrodes, the humidifier must be installed plumb and level.



**to Install Units Type HY05- HY30:**

- » Place the steam humidifier in its intended location, use a level to adjust position, and secure. See chapter "Unit Dimensions".
- » Attach the unit to the lower mounting fixtures.

**to Install Units HY45- HY116:**

- » Fix bracket at the intended location. See chapter "Unit Dimensions".
- » Mount the unit, adjust position using a level, and screw tightly into the mounting fixtures.
- » Attach the unit to the lower mounting fixtures.

If no suitable wall is present, we recommend construction of a free-standing console anchored to the floor.

### 5.1.2 Unit Dimensions HY05-HY45

View from below

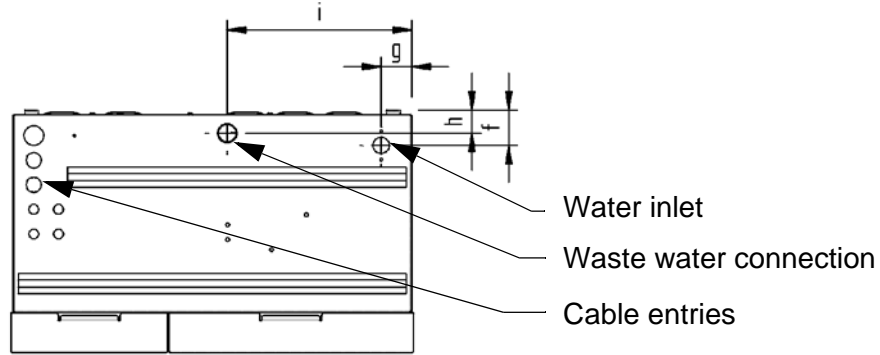

Rear view

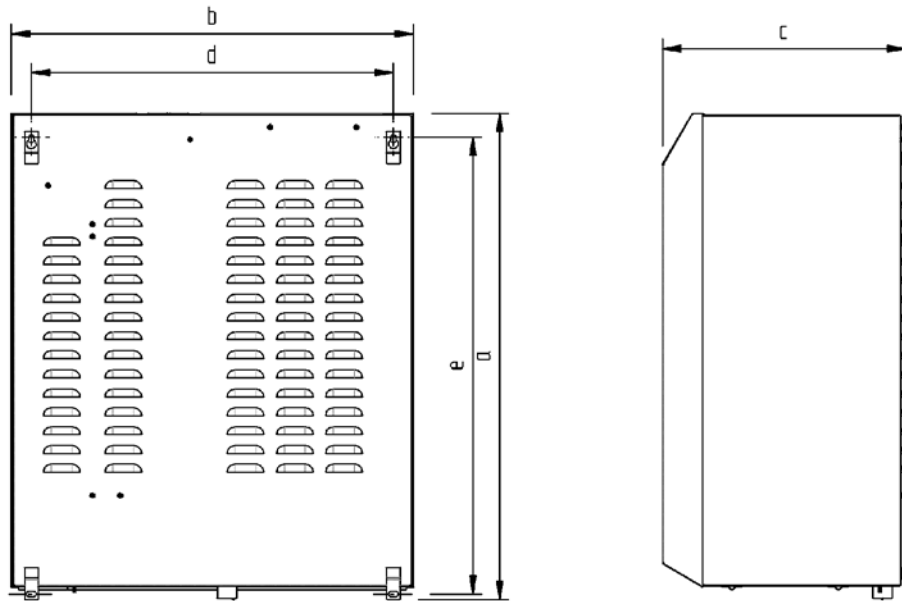

View from top

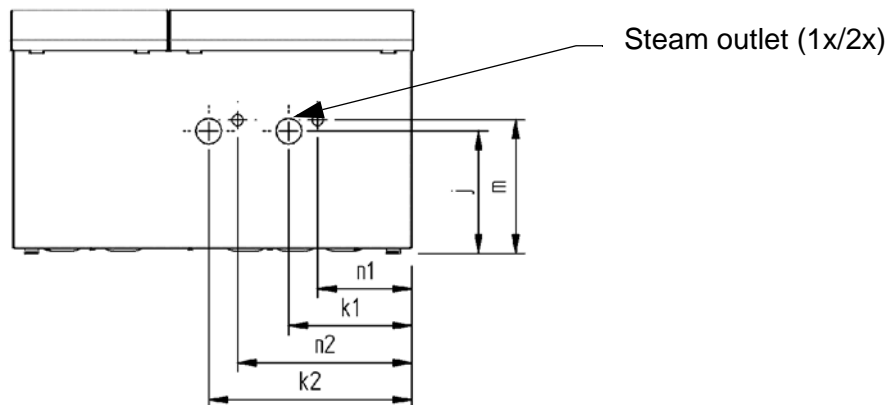

Type / Dimensions	a	b	c	d	e	f	g	h	i	j	k1	k2	m	n1	n2
HY05-HY08	481	449	216	415	438	43	35	35	120	120	103	-	147	65	-
HY13-HY23	654	520	284	486	619	63	35	38	210	152	136	-	184	96	-
HY30	710	560	327	515	665	58	50	38	250	172	156	-	197	106	-
HY45	788	653	405	588	742	68	50	48	300	209	200	330	227	153	283

Specifications in (mm)

### 5.1.3 Unit Dimensions HY60-HY116

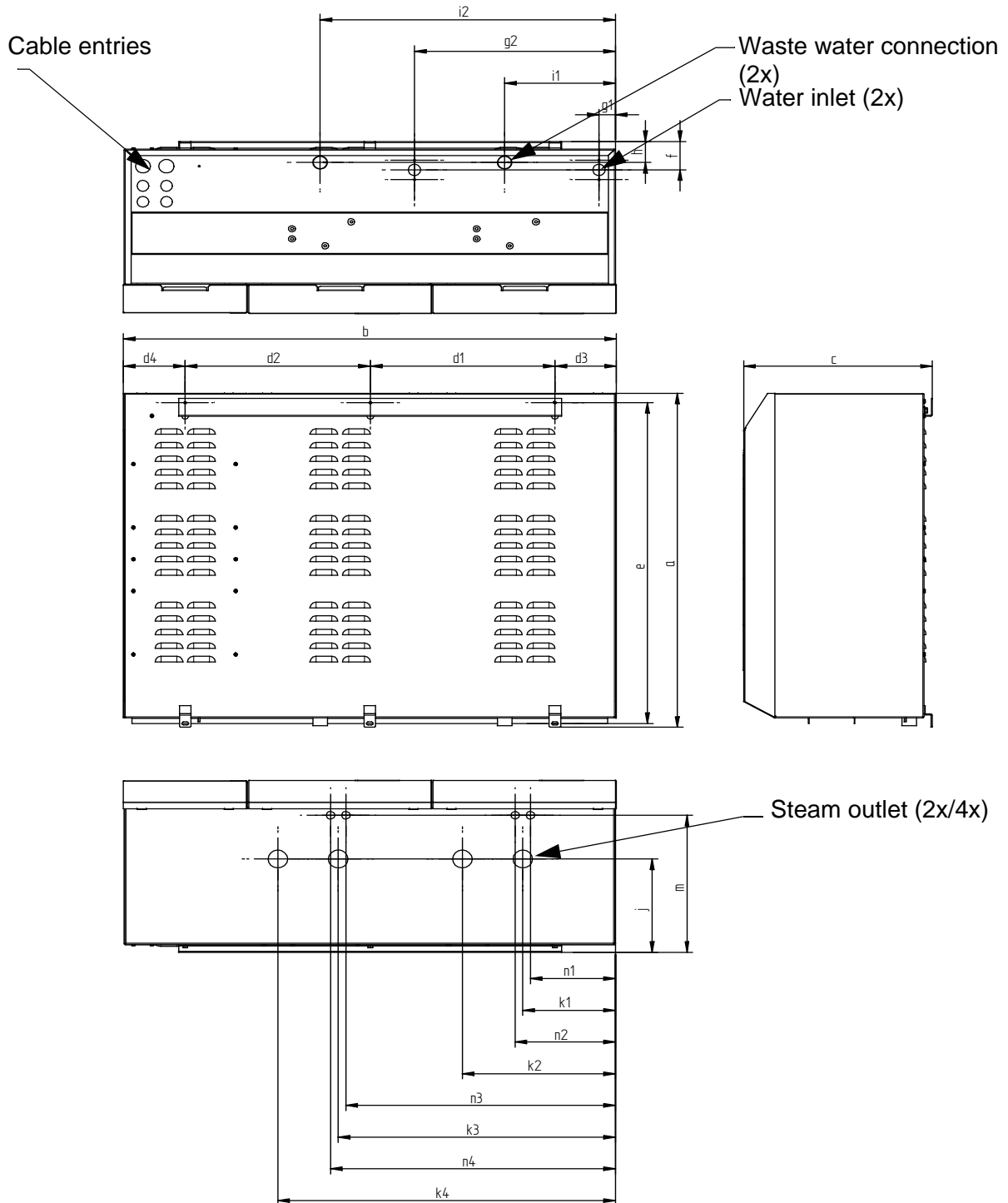

Type / Dims.	a	b	c	d1	d2	d3	d4	e	f	g1	g2	h	i1	i2	j
HY60	712	927	336	327	371	95	133	680	67	46	368	50	195	525	186
HY90-HY116	792	1061	404	398	398	132	132	758	67	35	432	50	238	635	220
Type / Dims	k1	k2	k3	k4	m	n1	n2	n3	n4						
HY60	157	488	-	-	204	110	441	-	-						
HY90-HY116	199	329	597	727	324	183	216	580	613						

Specifications in (mm);

\* HY60 only one steam outlet per zylinder

## 5.2 Fan Unit (optional)



**Note:** The fan unit should be positioned to avoid drafts. In general, a minimum height of 2 m is sufficient.

Install the fan unit directly on a wall.

Fan Unit	Type
for wall installation	VG 08, 17, 30



### Warning:

- During operation and a soon afterwards the steam nozzle is hot! If touched this can cause burns to the skin.
- During operation the cross-flow fan rotates. Do not touch the fan during operation.
- During operation hot steam discharges from the nozzle. In the field of the visible steam cloud contact can cause burns to the skin.
- During operation the cross-flow fan rotates. Do not touch the fan during operation.

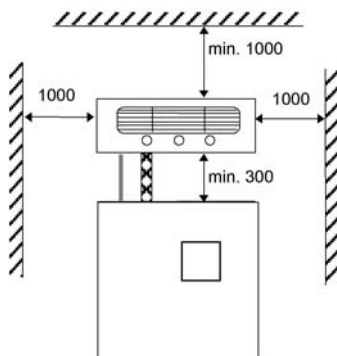

Front View Wall Installation

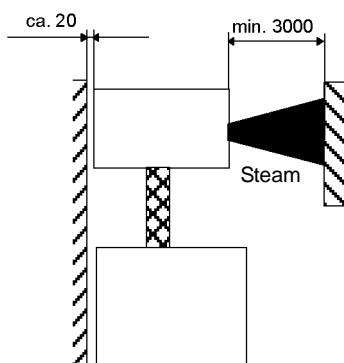

Side View Wall Installation

### 5.2.1 Fan Unit Type VG

- Install the fan unit over the steam humidifier.
- When employing multiple fan units, do not exceed a maximum distance of 5 m from the steam humidifier.
- Observe the clearances specified in the diagram below:

Technical Specifications Fan Unit VG				
Fan Unit		VG08	VG17	VG30
Quantity of Steam	[kg/h]	8	17	30
Steam Inlet	[mm $\phi$ ]	25	25	40
Condensate Outlet	[mm $\phi$ ]	12	12	12
Airflow Capacity	[cbm/h]	185	185	350
Nominal Output	[W]	35	35	67
Nominal voltage	[V]	230	230	230
Dimensions	W [mm]	441	507	550
	H [mm]	171	171	171
	D [mm]	180	237	277
Weight	[kg]	4,5	6	7
Sound Level (1m distance to the source of noise)	[dB(A)]	50	57	59

### 5.2.2 Fan Unit Cover

Covers (optional) for Types HY05 and HY30 are available to protect the steam and condensate hoses between the steam humidifier and the fan unit. The vertical distance between the humidifier and the fan unit is determined by the height of the cover (see Table of Dimensions H).

- » Drill two holes in the housing as specified in the following diagram.

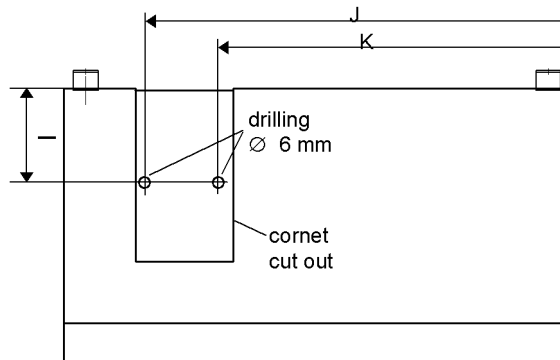

Type	H [mm]	I [mm]	J [mm]	K [mm]
HY05- HY08	175	80	373	266,5
HY13-HY23	280	105	422	310
HY30	280	105	452	340

- » Install the steam humidifier and fan unit on the wall (distance H). Diameter of bore  $\varnothing$  6 mm Panel cutout

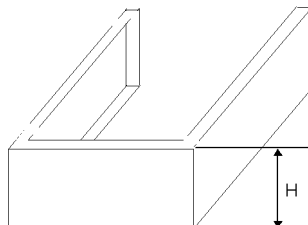

- » Secure the steam hose between the humidifier and fan unit with hose clamps
- » Also using a hose clamp, attach the condensate hose to the fan unit.
- » Run condensate hose along the rear of the unit to the water discharge. (Also see chapter "Water Discharge".)
- » Lay the loop of condensate hose 200 mm directly above the drain. The loop acts as a vapor barrier.

**Note:** Condensate cannot be fed back into the steam cylinder.



- » Slide cover between humidifier and fan unit.
- » Fasten cover with the two screws supplied. Screw from the steam panel outwards.

### 5.3 Absorption Distance $B_N$

The "absorption distance" ( $B_N$ ) is defined as the distance from the steam feed to where the steam is completely absorbed in the treated air. Inside the absorption distance, steam is visible as mist in the air stream.

Condensation may collect on anything installed inside the absorption distance.

Although steam outside the absorption distance ( $B_N$ ) is completely absorbed, it is not yet evenly diffused in the duct. If you plan to install any parts or devices inside the absorption distance, such as sensors or elbows, we recommend increasing the absorption distance using the formulae below. The absorption distances required for certain installed fittings are distinguished by separate symbols and calculated as a multiplier of the absorption distance  $B_N$ .

Absorption Distance	
$B_N$	for normal obstructions, such as sensors, ventilators, outlets
$B_C = (1,5...2) \times B_N$	for fine filters, heat registers
$B_S = (2,5...3) \times B_N$	for particle filters
$B_D = (2,5...3) \times B_N$	for humidity sensors, duct humidistats

The absorption distance has no fixed value, but depends on many factors. These are depicted in the absorption distance nomogram below.

#### 5.3.1 Determining the Absorption Distance

To determine the absorption distance, the following parameters are required:

- Air humidity before humidification  $x_1$  in g/kg.
- Air temperature after humidification  $t_2$  in °C (with steam humidifiers the change in air temperature due to humidification may be disregarded  $t_1$  or  $t_2$ ).
- Specific increase in humidity  $\Delta x$  in g/kg (can be determined in the h,x diagram)
- quantity of steam introduced  $\overset{o}{m}_D$  in kg/h.
- air speed  $w_L$  in m/s in air duct
- Total length  $l_D$  of the steam manifold installed in the air duct

Length  $l_D$  of the usable steam manifold depends on the dimensions of the air duct. The length of the absorption distance can be reduced by using multiple steam manifolds (also see section on the steam manifold).

**Method:**

Graphically determine absorption distance  $B_N$  using the absorption distance nomogram (also see Section „Absorption Distance Nomogramm“ on page 24). Enter the value of the parameters enumerated above into the respective quadrants. The resulting point of intersection indicates the value of the desired absorption distance  $B_N$ .

**Notes:**

Air humidity before humidification  $x_1$ : \_\_\_\_\_ [g/kg]  
Air temperature after humidification  $t_2$ : \_\_\_\_\_ [°C]  
Specific increase in humidity  $\Delta x$ : \_\_\_\_\_ [g/kg]  
quantity of steam introduced  $m_D^o$ : \_\_\_\_\_ [kg/h]  
air speed  $w_L$ : \_\_\_\_\_ [m/s]  
Total length of the steam manifold  $l_D$ : \_\_\_\_\_ [mm]

### 5.3.2 Absorption Distance Nomogram

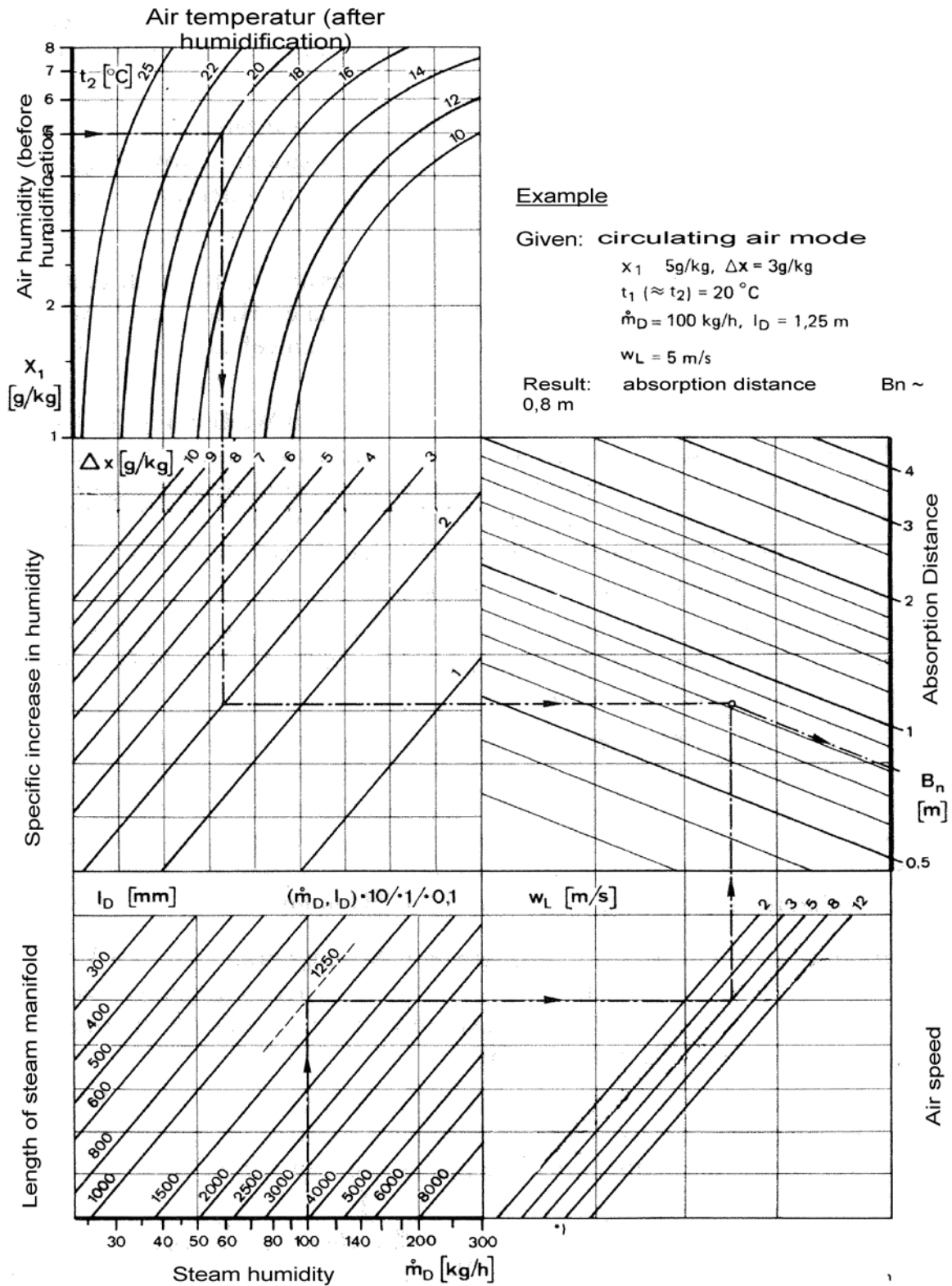

Source: Henne, Erich: Luftbefeuchtung (Air Humidification), 3<sup>rd</sup> Edition 1984 (Page 101), Oldenbourg Industrieverlag, Munich



## 5.4 Steam Manifold

### 5.4.1 Notes on Installation

#### Horizontal installation of steam manifold

These notes are based on a homogeneous Standard steam manifold installation:

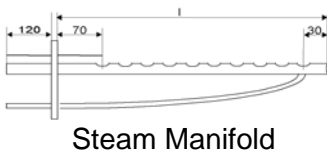
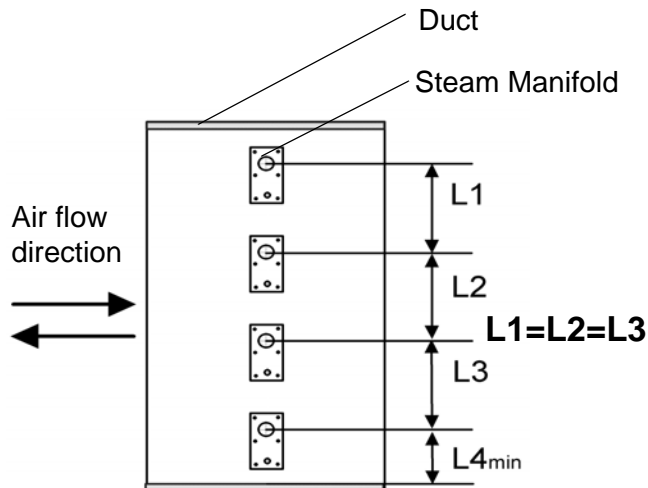

An even distribution of steam manifolds ensures a uniform steam distribution.

Please use the total height of the duct!

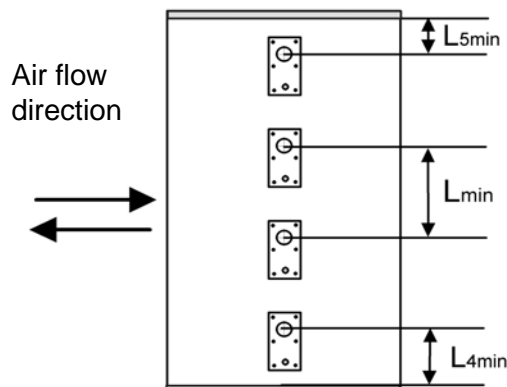

Minimum distances in order to avoid condensation:

**L<sub>min</sub> = 210mm**: distance „ steam manifold - next steam manifold“

**L<sub>4min</sub> = 120mm**: distance „lowest steam manifold - duct bottom“:**L<sub>5min</sub> = 120mm**: distance „highest steam manifold - duct ceiling“

Installations depending on special designs of air ducts:

Air duct	Positioning of steam manifolds	Sample																								
flat	Staggered vertically and laterally																									
very flat	<p>By tilting the steam manifold 30 - 45° towards the air flow direction, the minimum upper clearance can be reduced to 70mm.</p> <table border="1"> <thead> <tr> <th colspan="2">min. distances:</th> <th colspan="2">H1[mm]</th> <th colspan="2">H2[mm]</th> </tr> <tr> <th></th> <th></th> <th>30°</th> <th>45°</th> <th></th> <th></th> </tr> </thead> <tbody> <tr> <td>DN25</td> <td></td> <td>182</td> <td>168</td> <td>225</td> <td></td> </tr> <tr> <td>DN40</td> <td></td> <td>193</td> <td>179</td> <td>230</td> <td></td> </tr> </tbody> </table>	min. distances:		H1[mm]		H2[mm]				30°	45°			DN25		182	168	225		DN40		193	179	230		<p>very flat duct</p>
min. distances:		H1[mm]		H2[mm]																						
		30°	45°																							
DN25		182	168	225																						
DN40		193	179	230																						
narrow, high	Identical lengths one on top of the other. Staggered laterally if possible.																									
square	Identical lengths, staggered vertically and laterally																									
low, very wide	facing each other																									

**Vertical installation of steam manifold**

Steam manifold placement:

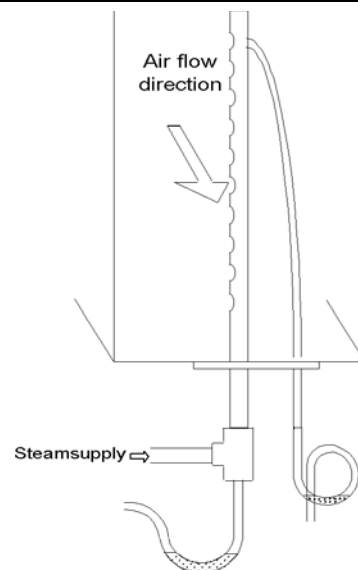

Horizontal installation of the steam manifolds is preferred. However, installation from below into the air duct is possible.

**Note:**



- Install the steam manifold horizontal with it ensure a clean steam out.
- Maximum allowable pressure in the air duct is 1200 Pa.
- On the return side, the maximum allowable negative air pressure is 500 Pa. Placement of the steam manifold on the supply side of the air duct is preferred.
- With high-pressure air-conditioning systems, the unit's drain hose system must be modified depending on the over pressure. When this is the case please consult HygroMatik.
- Install the steam manifold as close as possible to the steam humidifier in order to minimize steam loss through condensation.
- Depending on the design of the air duct, additional mounting of the steam manifold may be required. Shown installation and position dimensions are based on experimental values. Special environmental conditions could require adjustments.
- We note that the German Association of Engineers (VDI) Guideline 6022 specifies a water drain within the absorption distance inside the air duct.
- For steam bath applications: Install the steam manifold safe from contact with people in order to prevent injuries or burns. Do not install the steam manifold near a temperature sensor or inaccurate readings may result.
- Air flow rates over 3m/s can possibly lead to condensate drainage problems at the steam manifolds which may require adaptation measures.

**Length of steam manifold [mm]\*:**

I	220	400	600	900	1200	1450
DN25	x	x	x	x	x	x
DN40	x	x	x	x	x	x

\* special lenght on request

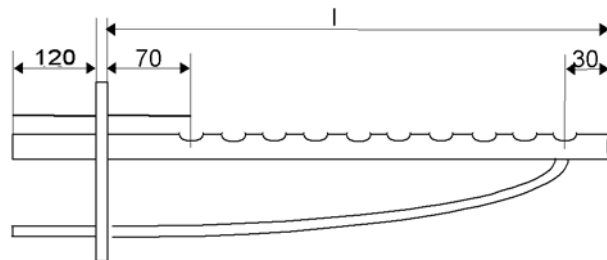

**Note:** At lengths of 600mm or more, steam manifolds are shipped with an extra alternative mounting fixture (Nut, M8) on the closed end.

The number and size of appropriate steam manifolds, as well as the nominal width of their respective steam and condensate hoses, are found in the tables below.

**HyLine:**

Type	Steam Manifold	Steam Hose	Condensate hose
HY05-HY17	1xDN25	DN25	DN12
HY05DS - HY17DS (for SPA)	1xDN40	DN40	DN12
HY23-HY30	1xDN40	DN40	DN12
HY45-HY60	2xDN40	2xDN40	2xDN12
HY90-HY116	4xDN40	4xDN40	4xDN12

**CompactLine:**

Type	Steam Manifold	Steam Hose	Condensate Hose
C6-C17	1xDN25	DN25	DN12
C10-DS, C17DS (for SPA)	1xDN40	DN40	DN12
C22, C30	1xDN40	DN40	DN12
C45**	2xDN40	DN40	DN12
C58	2xDN40	2xDN40	2xDN12

**HeaterCompact:**

Type	Steam Manifold	Steam Hose	Condensate Hose
HC3-12*	1xDN25	DN25	DN12
HC16-27	1xDN40	DN40	DN12
HC3-27 (for SPA)	1xDN40	DN40	DN12

**DBE:**

Type	Steam Manifold	Steam Hose	Condensate Hose
DBE 1-6	1x25	DN25	DN9
DBE 10-17	1x25	DN25	DN12
DBE 30	1x40	DN40	DN12
DBE 45	2x40	DN40	DN12

**HeaterLine:**

Type	Steam Manifold	Steam Hose	Condensate Hose
HL 6-12 *	1xDN25	DN25	DN12
HL 6-12 (for SPA)	1xDN40	DN40	DN12
HL 18-30	1xDN40	DN40	DN12
HL 36-45 **	2xDN40	1xDN40	1xDN12
HL 60-90 ***	2x(2xDN40)	2x(1xDN40)	2x(1xDN12)

\* For units HL 6 - 12 and HC3-12 HygroMatik delivers one adapter DN40 / 25 (but not for SPA applications)..

\*\* For units HL 36 - 45 HygroMatik delivers one t-connector for separating the steam on two steam manifolds.

\*\*\*HI 60.-90 are double units and consist of HI 30-45 units.

## 5.5 Steam Line



**Note:** When installing the steam hose, please pay attention to the following:

- The steam hose diameter may not be smaller than the steam outlet of the HygroMatik steam humidifier (do not restrict the cross-section, otherwise back pressure will increase).
- The steam hose must be without sags and kinks and be laid with a continuous slope of 5-10% (otherwise sags will be formed).
- The steam hose should be as short as possible. In case of lengths of over 5 m the hose should be insulated to avoid excess condensation.
- In the case that steam output is distributed on two steam manifolds the Y-pieces for the steam and condensate hose should be installed near the manifolds. If the installation is carried out in this way only one steam hose is necessary for the main part, loss of condensate will be decreased. If the installation is carried out in this way only one steam hose is necessary for the main part, loss of condensate will be decreased. In deviation of this the y-piece that is delivered ex works with a humidifier type C45, HL36, HL45 should be installed near the humidifier.
- Depending on how the hose is laid, hose clips should be set at intervals of approx. 500 mm.
- Allow access to the steam hose, so that it can be inspected later.
- In case of straight lengths of several meters, it is recommended to place the steam hose in temperature resistant plastic pipe (40 mm dia for hose DN25; 60 mm dia for hose DN40) or to use copper pipe.
- Device output, steam line installation, and the duct influence pressure condition in the duct. In an exceptional case this could mean to optimize the steam line installation.
- Only genuine HygroMatik hoses are capable of withstanding the operating conditions.  
Allow for minimum bending radii:  
Steam hose DN 25:  $R_{min} = 200 \text{ mm}$   
Steam hose DN 40:  $R_{min} = 400 \text{ mm}$

## 5.6 Cover Plate

HygroMatik flange plates may be used to neatly complete installation of the steam humidifier in the air duct.

Two-piece flange plates are available for the DN25 and DN40 steam manifolds.

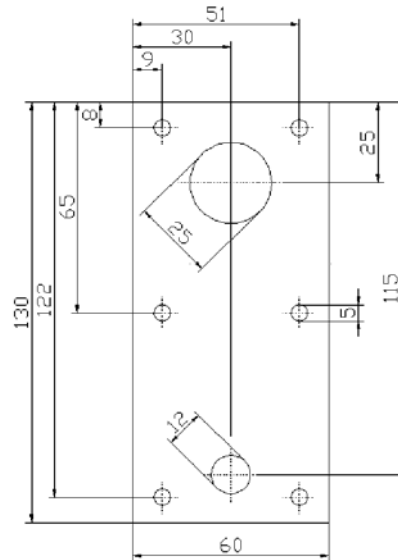

flange plate DN25 E-2604260

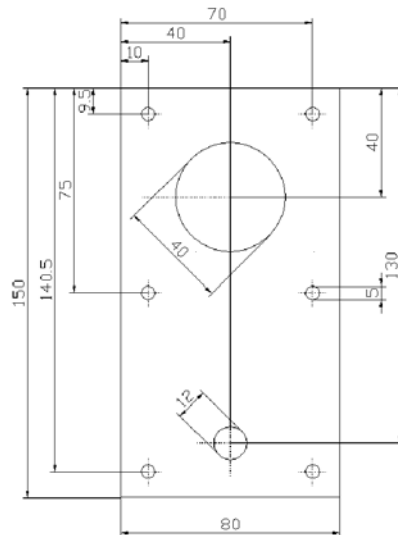

flange plate DN40 E-2604410

## 5.7 Drill Pattern

### Drill Pattern DN25 (not to scale)

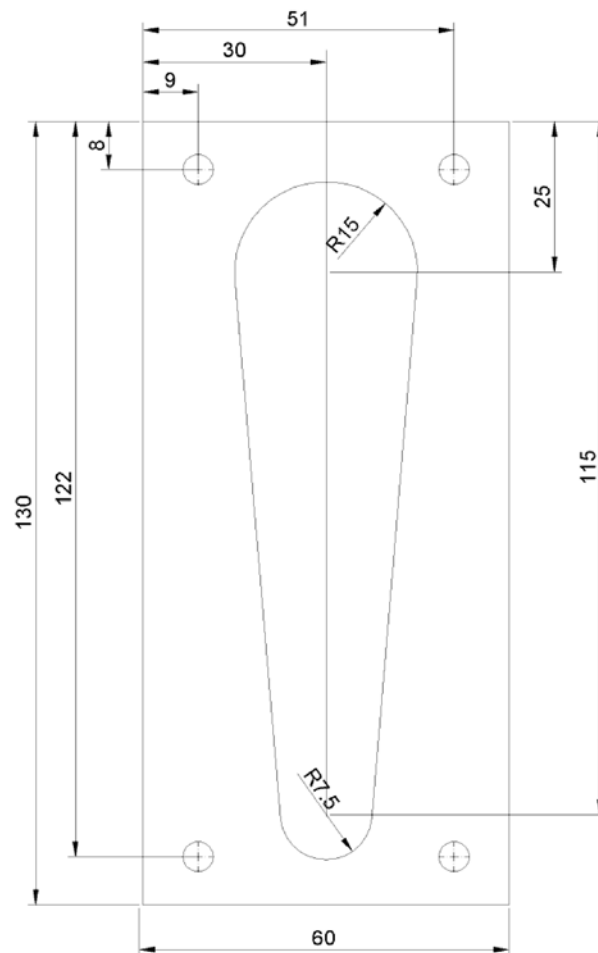

**Note:** Due to variable print media the dimensions are not to scale.

**Drill Pattern DN40 (not to scale)**

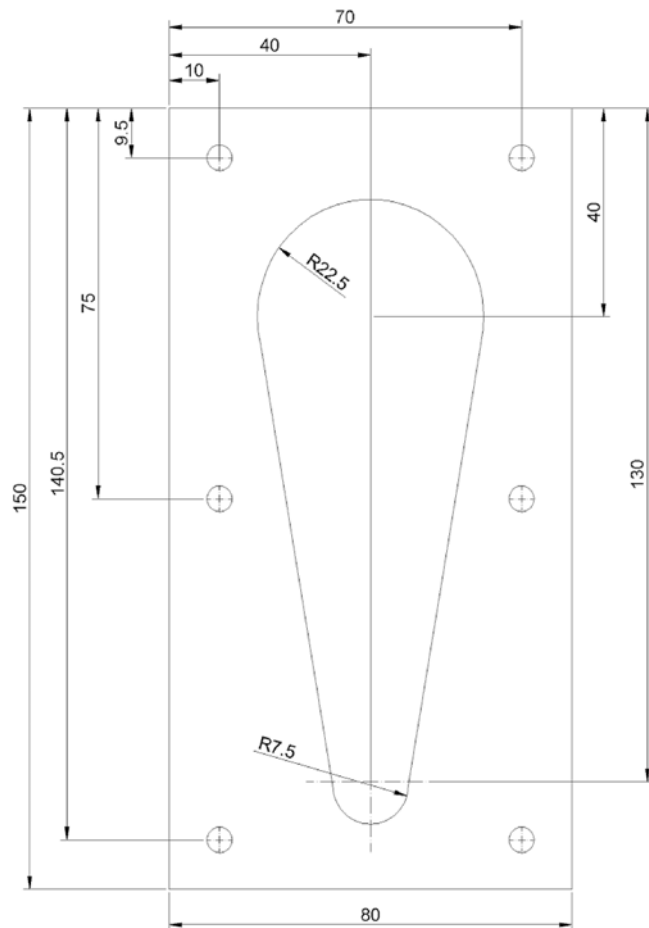

**Note:** Due to variable print media the dimensions are not to scale.



## 5.8 Condensate Hose



**Note:** When installing the condensate hose, please pay attention to the following:



**Warning:** To keep condensate from accumulating in the duct, make sure condensate can drain freely.

**If the steam manifold is positioned higher than 500 mm above the steam humidifier:**

- » Remove the condensate plug (12) from the connection fitting on the cylinder.
- » Lay the condensate hose at an approximate incline of 5-10% to the steam cylinder connection fitting, to allow the condensate to drain freely.



**Note:** It is recommended to form a loop of 200 mm diameter as a vapour trap provided there is enough space. Possible operating noises can be reduced in this manner.

**If the steam manifold is positioned lower than 500 mm above the steam humidifier:**

- » The condensate must be drained separately.
- » To prevent steam loss, lay a loop at least 200 mm in diameter.
- » To ensure condensate drainage, place the loop (vapor trap) as far away as possible below the steam manifold connection.
- » The condensate connection on the steam cylinder must be closed with a sealing cap.
- » Place hose clamps at intervals of at least 500 mm, depending on how the hose is laid.

## 5.9 Types of Installation

**If the steam manifold is positioned higher than 500 mm above the steam humidifier:**

- » Lay the steam hose at a height of at least 400 mm above unit and then connect to the steam manifold with a constant rise or fall.
- » Lay condensate hose with a slope to the steam cylinder.

- » If enough space is available, lay a loop as a vapor trap. The steam manifold must be at least 500 mm from the loop.

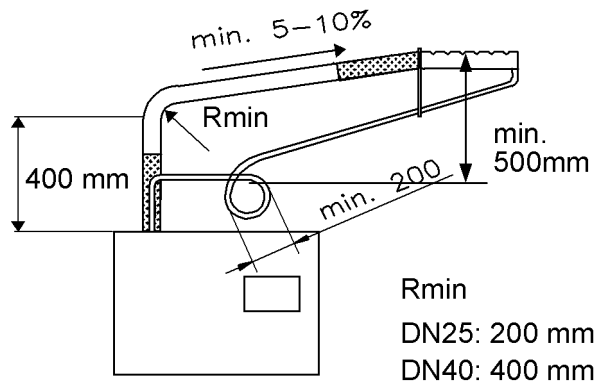

**If the steam manifold is positioned lower than 500 mm above the steam humidifier:**

- » Lay steam hose at a height of at least 400 mm above unit and then connect to the steam manifold with a constant fall.
- » Lay condensate hose with a loop of 200 mm diameter (vapour trap) to the drain. The distance between vapour trap and steam manifold should have at least 500mm.

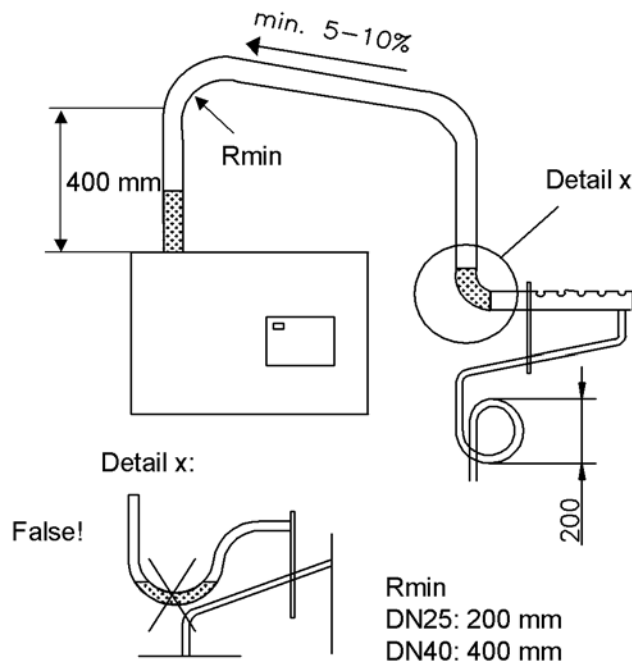

- » Lay the loop of condensate hose 200 mm directly above the drain. Detail x

## 5.10 Steam Solenoid Valves

When humidifying a number of loads, which are to be controlled separately, using a single steam humidifier, steam solenoid valves can be included in the steam hoses. Valve control has to be provided by the customer.

- Install the vertical risers with flow from bottom to top.
- The best position is just above the steam humidifier.

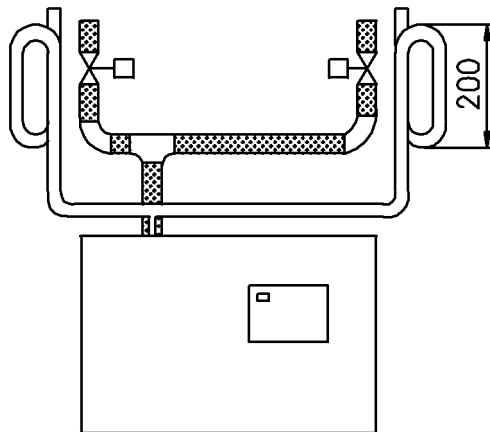

Installation of Steam Solenoid Valve

## 5.11 Unit Installation Check



**Attention:** This unit may only be operated by qualified and properly trained personnel.

Please check the installation using the following list:

- Does unit hang vertically?
- Are wall distances to the unit within the range
- Does steam hose have a slope of 5-10%?
- Is condensate hose installed with a loop of min. 200 mm?
- Is steam manifold positioned correctly? Are all bolts and clamps tightened?

## 6. Water Installation



**Warning:** When installing the water installation, note the following:

- Have all work performed by a professional.
- Disconnect power supply before installation.
- Obey local public utility regulations
- Verify that necessary safety measures have been taken – in compliance with either German Technical and Scientific Association for Gas and Water (DVGW) guidelines (DIN EN1717) or local regulations – to eliminate backflow of polluted water into drinking water treatment facilities. This can mean installing a backflow preventer.
- Use feed water without chemical additives and with a conductivity between 200 and 800  $\mu\text{S}/\text{cm}$  only. Above conductivity levels of 800 $\mu\text{S}/\text{cm}$  to a maximum of 1250 $\mu\text{S}/\text{cm}$  and below conductivity levels of 200 $\mu\text{S}/\text{cm}$  to a minimum of 125 $\mu\text{S}/\text{cm}$ , special adjustments are required. In this case please contact HygroMatik.
- The water supply temperature may not exceed 40° C.
- Water installation pressure: 1 - 10 bar (100 x 10<sup>3</sup> to 100 x 10<sup>4</sup> pascal).
- Blow-down water must be able to drain.
- For water installation please use the water connecting hose that is delivered with the unit.

### 6.1 Operation with Softened Water



**Warning:** Unless special measures are taken, feeding softened water into the HygroMatik steam humidifier is dangerous. It can cause

- unacceptably high conductivity
- the formation of salt bridges between the electrodes and the electrode leads on the inner surface of the top part of the steam cylinder
- foaming in the steam cylinder

Salt bridges cause electrical arcs. These are indicated by the presence of black grooves in the top part of the cylinder. The top part must be replaced to prevent further damage to the cylinder material, as well as short circuits which trip main circuit breakers.

Foam comes into contact with the maximum water level sensor electrode and triggers a signal indicating the cylinder is filled to capacity, even though this is false and the nominal current has not yet been reached.



**Note:** Please contact HygroMatik if you wish to operate the unit with softened water.

- If using a water softening system, we recommend diluting the softened water with normal tap water to produce an overall hardness between 4-8°dH. This value can be set lower if the water does not foam.  
When blending softened water with deionized water (conductivity = 5-20  $\mu\text{S} / \text{cm}$ ) it is to ensure that the mixture neither foams nor is too low in conductivity.
- When feed water contains softened water, the level of conductivity is typically higher at operating temperature. Install a HygroMatik "cylinder star" to extend the service life of the electrodes.

## 6.2 Water Supply

- » Install a shut-off valve (SV) in the supply line.
- » Install a water filter (WF) if water quality requires it.



**Note:** Shut-off valve (SV) and water filter (WF) are not supplied with the unit

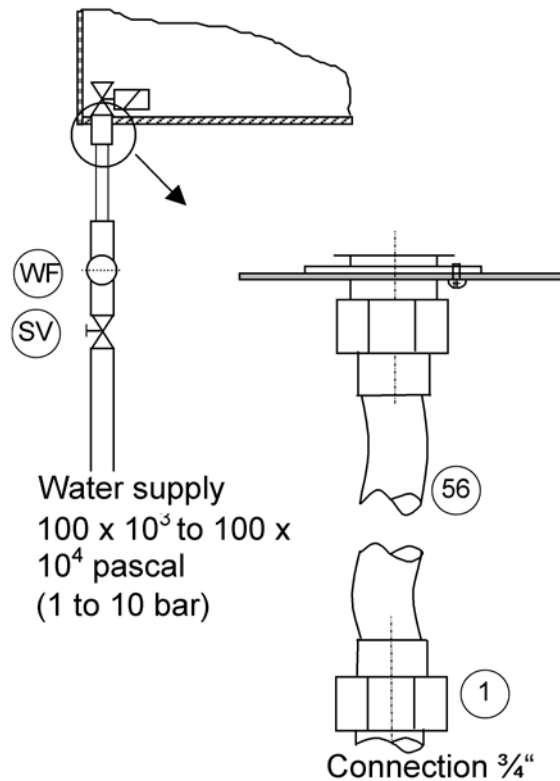

- » HygroMatik provides a water hose (56) with a cap nut at both ends which can be used for water installation.

Install as follows:

- » Screw and tighten the cap nut with its inner seal ring around the water supply screw connection that protrudes from the base.



**Note:** Tightening too much will destroy the fitting. The valve strainer must be placed inside the solenoid valve.

- » Use a cap nut (internal thread 3/4") with inner seal for a customer-provided water installation.

## 6.3 Water discharge

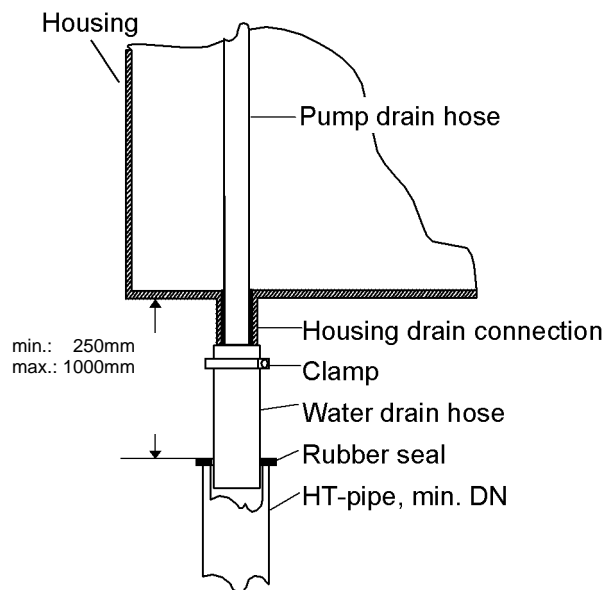

**Warning:** During blow down hot water with a temperature of about 95°C is being drained. If touched this can cause burns to the skin.



**Warning:** Pay attention for free and non-pressure drainage of the water! During blow down up to 0,3 L/sec are being drained. For water discharge, we recommend installation of a flexible water drain hose. Humidifier and wastewater discharge must be on the same pressure level.

Please note:

- Do not bend the drain hose.
- Install discharge line and drain pipe made from temperature resistant material (to 95° C).

Install water discharge as follows

- Loosely insert a length of 1 1/4 " drain hose, approx. 250 - 1000 mm, into a drain pipe with a minimum inner diameter of 40 mm and seal with a rubber gasket.
- Fit water drain hose over the pump drain hose and fasten to the housing drain connection.

A grounding clip is fixed on the inner surface of the housing drain connection. The end of the pump drain hose is pushed into this clip. During blow-down, the grounding clip is in direct contact with the water and shunts potential residual electric currents away from the housing.

There is a 3mm-wide crack between the pump drain hose jacket and the inner surface of the housing drain connection. If water

collects in the base plate, it will flow through this crack into the drainage system.

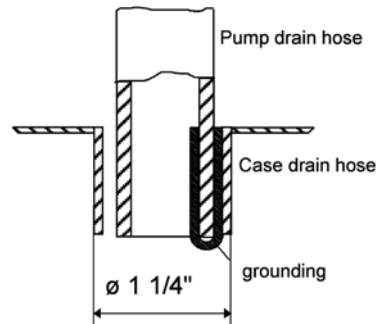

## 6.4 Water Installation Check

Go down the following water installation checklist:

- Are all screws and clamps properly tightened?
- Is the water supply pipe flushed?
- Was the water installation correctly installed?
- Can the blow-down water drain freely?
- Was the water discharge correctly installed?
- Is there no leakage from the water supply pipe and water discharge?



**Warning:** Flush the water supply pipe before connecting to the solenoid valve, especially a newly installed pipe. This prevents premature damage.

## 7. Electrical Connection



**Danger, Hazardous Voltage:** All work related to electrical installation to be performed by authorized personnel only (electricians or professionals with equivalent training). The customer is responsible for checking qualifications.



**Danger, Hazardous Voltage:** Do not plug the steam humidifier into the power grid until after all installation work has been completed.



**Warning:** The electronic components of the humidifier control are very sensitive to electrostatic discharges. In order to protect these components during any type of installation, steps must be taken to guard against damage from electrostatic discharge (ESD protection).



**Warning:** For electrical installation, note the following:

- Disconnect power supply before installation and protect against restart.
- Verify the absence of electric current.
- Make sure the unit is switched off before installing or removing the display plate or basic PCB.
- Professionally lay electrical connector cable.
- Install the electrical connections according to the wiring diagram.
- For units with rated power over 33 kW, only a permanent connection to a permanent wire is allowable (German Association for Electrical, Electronic & Information Technologies [VDE] Standard 0700 Section 98).
- Verify that all terminals have been tightened.

### 7.1 Electrical Installation

- » Fuses must have a contact gap of at least 3mm per pole.
- » Install a separate main connection for each steam cylinder, complete with main contactor, main switch, etc.
- » Connect potential equalization to the outer ground bolt.
- » Observe the German Association for Electrical, Electronic & Information Technologies [VDE] Standard 0100 when selecting a connection cross section.
- » Install main power supplies as follows:



Type	Standard Main Power Supply
HY05 - HY45	1 x 400V/3Phase/N
HY60 - HY116	2 x 400V/3Phase/N
C01, C02	1 x 230V/1Phase/N
C06 - C58	1 x 400V/3Phase/N
MS5, MS10	1 x 400V/3Phase/N
MS5	1 x 230V/1Phase/N
DBE 2	1 x 230V/1Phase
DBE 6-45	1 x 400V/3Phase/N

Other voltages are available on request.

We recommend employing medium blow main fuses (applicable only to the grid voltages above). See table below indicating maximum power usage for each circuit protection:

When using fault current circuit breakers please use a separate one for the humidifier.

**HyLine:**

Type	Power Usage	Circuit Protection
HY05	5,4 A	3 x 6A
HY08	8,7 A	3 x 10A
HY13	14,1 A	3 x 16 A
HY17	18,4 A	3 x 20 A
HY23	24,9 A	3 x 35 A
HY30	32,5 A	3 x 35 A
HY45	48,8 A	3 x 63 A
HY60	2 x 32,5 A	6 x 35 A
HY90	2 x 48,8 A	6 x 63 A
HY116	2 x 62,8 A	6 x 63 A

**CompactLine:**

Type	Power Usage	Circuit Protection
C01	3,3A	1 x 6A
C02	6,5A	1 x 10A
C06	6,5 A	3 x 10 A
C10	10,8 A	3 x 16 A
C17	18,4 A	3 x 20 A
C22	23,8	3 x 35 A
C30	32,5 A	3 x 35 A
C45	48,8 A	3 x 63 A
C58	62,8 A	3 x 63 A

**MiniSteam:**

Type	Power Usage	Circuit Protection
MS5, 230V/1/N	15,7 A	1 x 16 A
MS5, 400V/3/N	5,4 A	3 x 6 A
MS10, 400V/3/N	10,8 A	3 x 16 A

**DBE:**

Type	Power Usage	Circuit Protection
DBE1	3,3 A	1 x 6 A
DBE2	6,5 A	1 x 10 A
DBE6	6,5 A	3 x 10 A
DBE10	10,8 A	3 x 16 A
DBE17	18,4 A	3 x 25 A
DBE30	32,5 A	3 x 35 A
DBE45	48,8 A	3 x 63 A

**7.2 Cable Connections**

The table below shows the cable connections provided in electrode steam humidifiers:

Unit	Connection M16	Connection M25	Connection M32
HY05, HY08	4	3	-
HY13, HY17, HY23, HY30, Hy45	4	2	1
HY60, HY90, HY116	-	4	2
C01, C02	4	1	-
C06	3	2	-
C10	3	3	-
C17, C30	4	3	-
C45, C58	4	2	1
MS5, MS10	-	2	-

Characteristics of metric cable connections:

Thread	across-flats dimensions [mm]	for cable diameter [mm]
M16x1,5	19	4,5 - 10
M25x1,5	30	9 - 17
M32x1,5	36	11 - 21

### 7.3 Fan Unit

- » Connect fan unit according to the wiring diagram.

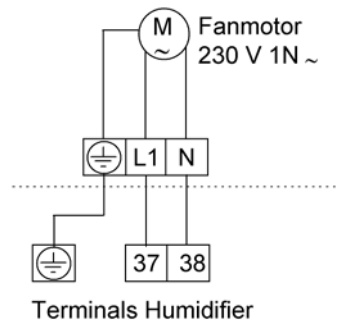

The fan unit operates in parallel with the humidifier.



**Note:** Terminals 37 and 38 are only installed if the option „fan unit“ is ordered.

## 7.4 Safety Interlock



**Note:** Install contact interlocks, i.e. max. hygostat, vane relay, pressure controller, air interlock, in series between terminals 1 and 2.



**Warning:** A max-hygostat should be installed in the safety interlock. The max-hygostat acts as a safety device in case the humidity sensor malfunctions.



**Warning:** Contacts laid between terminals 1 and 2 must be potential free and rated for 230V switches.

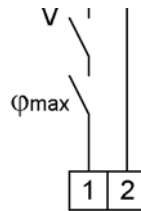

## 7.5 Wiring Diagram

Please remove the wiring diagram from the technical manual supplied with the control used with your humidifier. Every steam humidifier comes with one technical manual for the unit and one for the control.

## 7.6 Electrical Installation Checklist

Perform electrical installation checks in compliance with customer site requirements and public power utility regulations:

- Is the power grid voltage compatible with the voltage on the name plate?
- Have all electrical connections been made according to the terminal connection diagram?
- Have all electrical cable and plug connections been properly tightened?
- Are all electrical socket connections secure?
- Is the unit grounded?

After this check the unit can be switched on.



**Warning:** The unit must be closed and locked. This guarantees that the cover is grounded. (only humidifier type HyLine and MiniSteam)



**Note:** For initial operation, control, service, malfunctions, and circuit diagrams, consult the operation instructions for the Hygro-Matik-controls.

## 8. Commissioning



**Warning:** This unit is only to be started by qualified personnel.

### Switching off steam humidifier



**Warning:** Before starting up the unit, make sure you know how to switch it off.

- » Switch off unit by setting control switch to “0”
- » Close water supply stopcock valve.

### Check of electrical wire connections

- » Check that all electrical wire connections, including heater element wire connections, are tight and secure.
- » Check cylinder seating, and if necessary steam and condensate hose clamps.

### Switching on Steam Humidifier

- » Switch on main breaker.
- » Open water supply stopcock valve. Operating pressure  $100 \times 10^3$  to  $100 \times 10^4$  Pa (1 to 10 bar overpressure).
- » Switch on unit by setting control switch to “I”.
- » Set control of initial operation check to humidity demand.

The following functions are operating:

- The unit performs a self-test. If the control includes a display, the message “self-test” is displayed.
- When there is a demand for humidity, the water inlet solenoid valve opens and feeds water into the steam cylinder.
- Initiation of steam production can take up to 20 minutes.

Let all electrically-driven operations run to completion.

As soon as the solenoid valve begins replenishing the water periodically, the steam humidifier operates at steady nominal output and the cold start sequence is complete.

- » Monitor the unit and let it operate for 15 to 30 minutes. If leaks appear, switch off the unit.
- » Repair leaks, and in doing so:



**Attention, Hazardous Voltage!** Follow safety instructions for work on live components.

## 9. Maintenance

The HygroMatik steam humidifier is easy to maintain. However, inadequate or improper maintenance can lead to operational malfunctions. Perform regular maintenance to give your unit a long life span.



**Warning:** When performing maintenance work, please note:

- During operation and also for a while after switching off the unit the steam cylinder is hot. Before touching the cylinder, check its temperature.
- Drained cylinder water could have a temperature up to 95°C.
- Leakages within the humidifier could lead to leakage currents.
- The unit is only to be serviced by qualified, authorized personnel.
- Observe safety notes.
- Switch off the unit before maintenance and protect against restart.
- After maintenance work, have qualified personnel check that the unit is operating safely.

The steam humidifier's performance and maintenance intervals primarily depend on the water quality (carbonate hardness, conductivity) and the quantity of steam produced since the last maintenance. Abnormal water quality can shorten or lengthen maintenance intervals. Ongoing maintenance intervals can be estimated based on the amount and type of residue found in the steam cylinder.

Indications that cylinder maintenance is required immediately include:

Control	Indicator
Basic	maintenance message: <b>red and green LED</b> are blinking: Unit has switched itself off automatically.
Comfort/ Comfort Plus	<b>Maintenance</b> message on the display ( <b>red and green LED</b> are blinking). Unit has switched itself off automatically*.

### 9.1 Maintenance Work

Mineral deposits precipitate and crystallize very differently in different types of water, even when two types have the same conductivity and hardness levels (the various constituents in the water interact differently).

Instructions on maintenance and cleaning intervals, or on electrode service life, are based entirely on empirical data.

Cycle	Maintenance Work
<b>4 Weeks after initial operation</b> (with normal water quality)	Visual inspection of electrical and mechanical connections. Remove mineral deposits from steam cylinder, water drain hose and blow-down pump  Check electrodes for erosion
<b>Semiannually</b> (with normal water quality and "normal" operation = 8h/day)	Visual inspection of electrical and mechanical connections  Remove mineral deposits from steam cylinder, water drain hose and blow-down pump.  Check electrodes for erosion

In most cases, the conductivity levels given in Section "Directions for Use" of these instructions can be considered normal. Individual parameter setting of the control may be necessary.

In extreme cases, water pretreatment may be necessary (softening by dilution to approx. 4 - 8 °dH; decarbonization/partial desalination to achieve target reductions in carbonate hardness). HygroMatik would be pleased to refer you to companies specializing in water treatment systems.

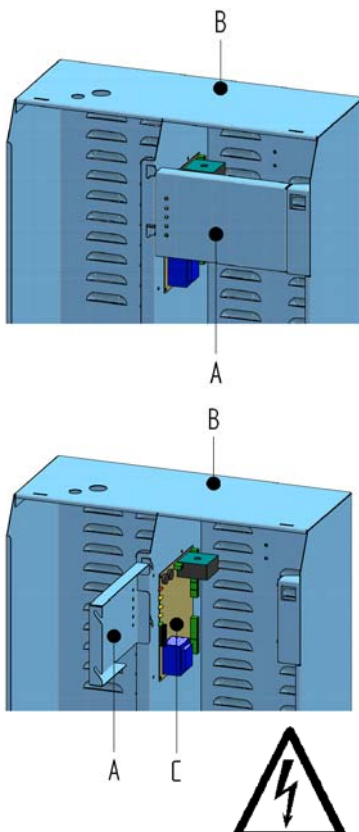

## 9.2 Access Electrical Enclosure

- » Remove cover from humidifier (B) and lift display plate (A) of guiding.
- » Turn display plate (please see sketch) and hang up display plate by using the „front guiding“.
- » The basic PCB (C) is now accessible.

**Danger, Hazardous Voltage:** Make sure the unit is switched off before installing or removing the display plate.

### 9.3 Removing and Cleaning the Steam Cylinder



**Warning:** Please follow the detailed instructions in these operating instructions! The unit is only to be serviced by qualified, authorized personnel. Note the warnings and safety notes in the operating instructions. Failure to observe warnings and safety notes may result in injury, serious injury or death, and/or damage to the unit. The steam cylinder may still be hot when you begin maintenance work. Handle carefully!



**Note:** After a longer period of operation the steam cylinder could shrink a little. This doesn't matter but could lead to tightness discrepancies when only one half of the cylinder is being exchanged. Therefore we recommend not to change only one half of the cylinder but a complete cylinder.



**Warning:** Both the clamps that fix the steam cylinder halves and the electrodes have sharp edges and angles that possibly could lead to cut injuries.

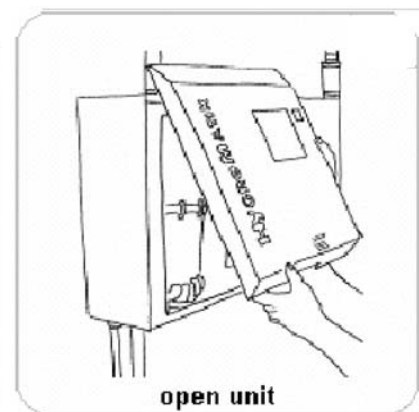
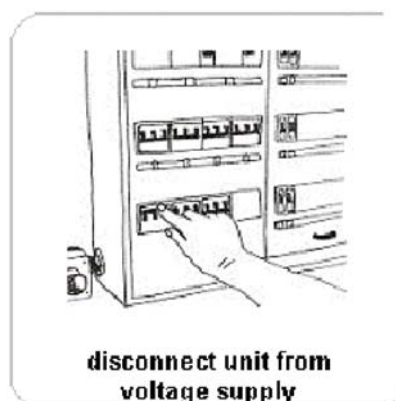
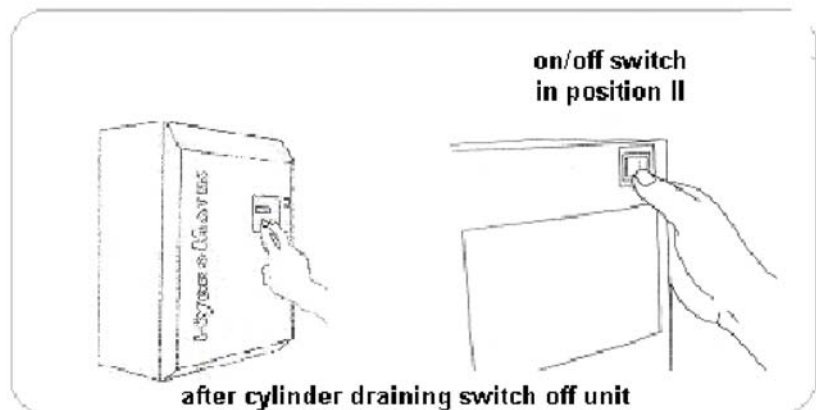



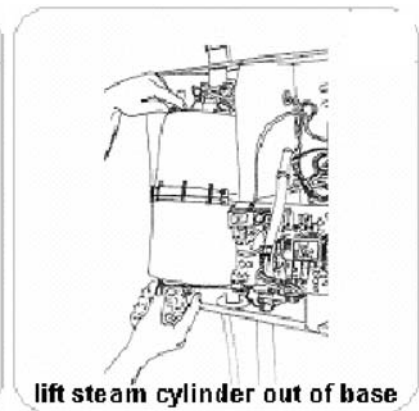
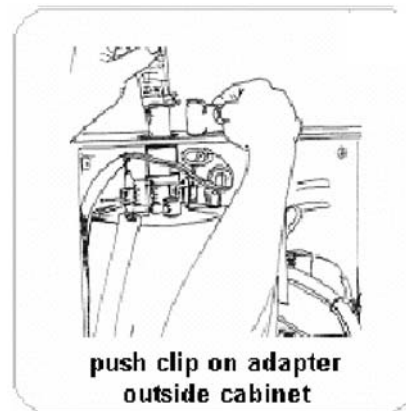
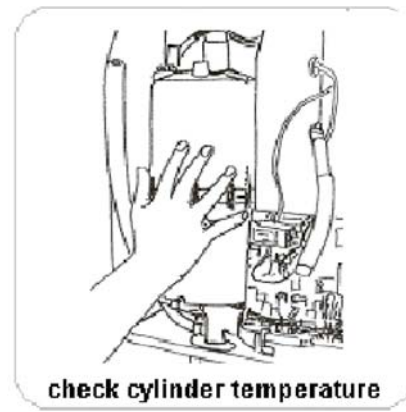
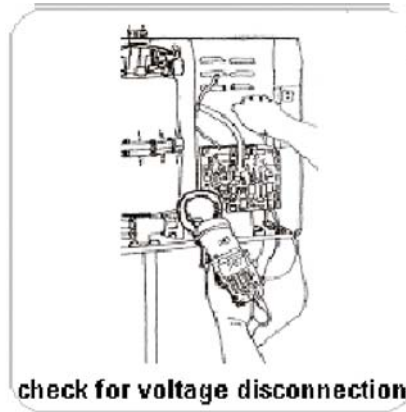

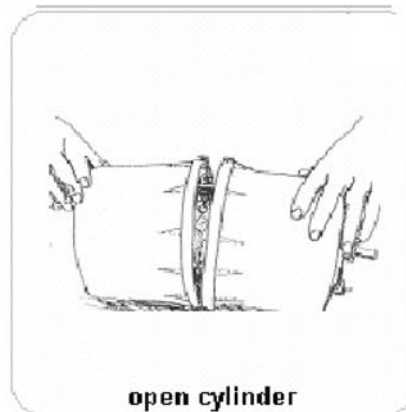
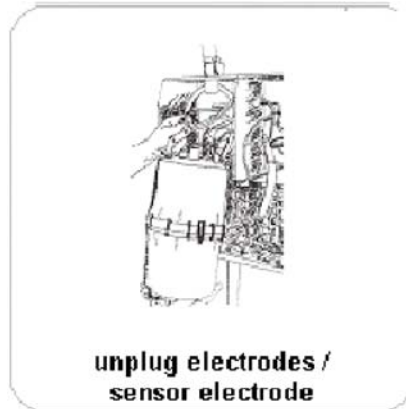

**Warning:** Check the inside of the top part of steam cylinder for crust build-up and possible salt bridges (black grooves between the electrode leads). If present, wash away completely .



**Note:** If electrical arcs have burned deep grooves in the material, the top part of the cylinder must be replaced.



**Warning:** Clean the sensor electrode until it is bright.

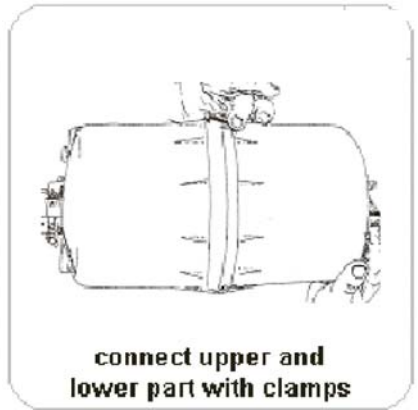

**Note:** When putting the cylinder back together, the joints and reinforcements of both sections must fit together snugly.



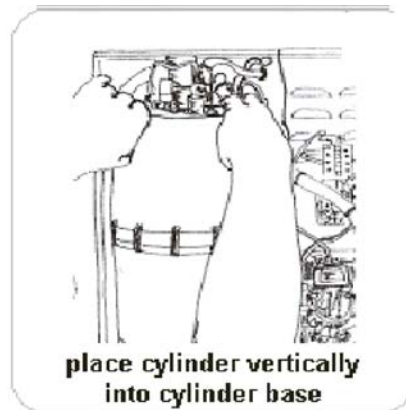

**Warning:** Before attaching the electrode plugs please make sure that they are free of corrosion. If not please replace them. The plug must be pressed down onto the electrode as far as it will go.



**Note:** Connect plugs to the correct electrodes. Note the color of the knurled nut.



**Note:** Condensate connection must be showing in the front on the left.



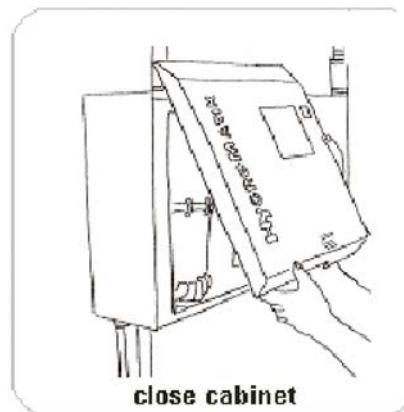
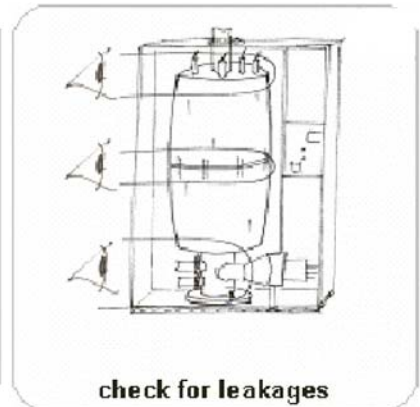

**Warning:** The unit must be closed and locked. This guarantees that the cover is grounded. (Only with humidifier type HyLine and MiniSteam)

Switch on the unit and check for leaks after 15-30 minutes of operation.

#### 9.4 Electrode wear

Electrode wear depends on:

- feed water composition and conductivity.
- the quantity of steam produced.

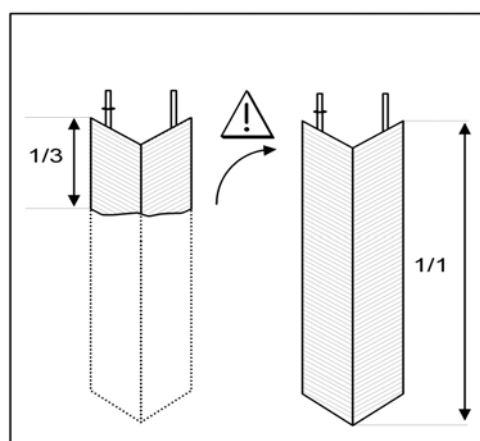



**Warning:** At the latest, electrodes must be replaced if a maintenance message is displayed. The maintenance message appears after one hour of operation at maximum water level. The humidifier switches itself off. Also see Section "Maintenance." When the electrodes are less than 1/3 to 1/2 of their original length, replace them.

### 9.4.1 Original Electrode Lengths

Original lengths of HygroMatik large area stainless-steel electrodes are:

#### HyLine:

Type	HY05-HY08	HY13-HY60	HY90-HY116
Length [mm]	155	235	300

#### CompactLine:

Type	C01	C02	C06	C10	C17-45	C58
Length [mm]	115	80	125	155	235	300

#### MiniSteam:

Type	MS5	MS10
Length [mm]	125	155

### 9.4.2 Uneven Electrode Lengths

In most case, the longer electrode(s) will not be supplied with electricity for a time. Therefore they will not wear. The cause of the problem, such as a tripped circuit breaker, can be repaired. However, since the shorter electrode(s) have a greater specific load, the electrodes continue to wear unevenly.



**Note:** Replace electrodes with significantly uneven wear. Check the power supply (breaker, voltage drop). Also see electronic operation, Section "Malfunctions."

## 9.5 Replacing Electrodes





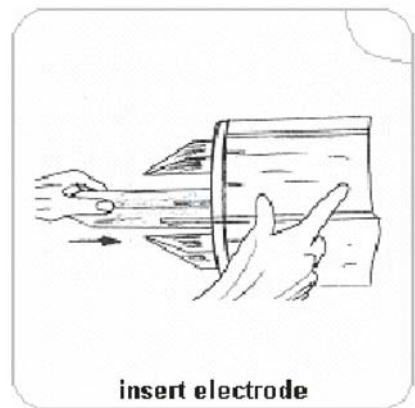
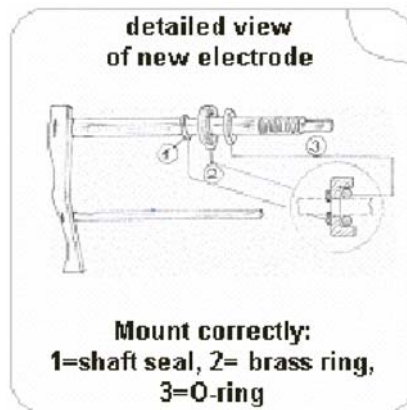

- » Remove and open cylinder, as described in Section "Removing and Cleaning Steam Cylinder."
- » Loosen knurled nuts (5) and remove electrodes (48).
- » Install new electrodes and hand tighten the nuts.

Use solvent-free, HygroMatik-quality o-rings (for flange, cylinder base and steam hose adapter).

- » Assemble steam cylinder and place it into cylinder
- » Connect plugs (4) directly to the electrodes (48) (with gray, red and black knurled nuts). It is not necessary to detach the knurled nuts!



**Warning:** The plug must be pressed down onto the electrode as far as it will go.



**Note:** Connect plugs to the correct electrodes. Pay attention to the color of the knurled nut.

- » Attach plug (8) to the sensor electrode. (Knurled nut - gray)
- » Switch breaker back on.
- » Switch on the unit and check for leaks after 15-30 minutes of operation.

If leakage occurs, switch off power supply and follow safety instructions for work on live components.



**Note:** In the following cases:

- the electrodes must be frequently replaced,
- black slime collects inside the cylinder, or
- there is "lightning" in the cylinder,

the conductivity of the water is too high or it isn't decanted often enough. In this case please contact HygroMatik.

## 9.6 Cleaning the Blow- Down Pump

- » Remove cylinder
- » Detach e-cable from the pump.
- » Detach adapter (30) from the pump.
- » Loosen screws (44) and remove the pump from the base.
- » Open the pump (bayonet lock).
- » Remove residues from the drain hoses and pump (if necessary replace o-ring or housing if these components are no longer in excellent condition).
- » Reassemble the pump.
- » Moisten o-ring (31) and insert in the side connection of the base.
- » Push pump into the base and mount tightly with screws (44).
- » Moisten o-ring (31) and insert in adapter (30).
- » Fit adapter (30) over the side connection of the pump.
- » Connect e-cable to the pump.
- » Install cylinder.
- » Switch on the unit and check for leaks during operation.

If leakage occurs, switch off power supply and follow safety instructions for work on live components.



## 9.7 Cleaning the Water Inlet Solenoid Valve

### Removal

- » Shut off water supply and loosen water installation hose connection.
- » Remove cylinder please also see chapter „Removing and Cleaning Steam Cylinder“
- » Loosen connecting hose (21) from the base.
- » Detach e-cable from the solenoid valve.
- » Loosen solenoid valve mounting screws (28).
- » Remove solenoid valve from the borehole.
- » Clean inlet section of solenoid valve and remove fine mesh filter (29) from the solenoid valve, clean and replace if needed.

### Installation

- » insert fine mesh filter (29).
- » Place solenoid valve with seal in the borehole of the unit housing.
- » Attach solenoid valve tightly with screws (28).
- » Screw on water installation hose.
- » Connect e-cable to the solenoid valve.
- » Attach connecting hose (21) to the base.
- » Install cylinder.
- » Turn on the tap.
- » Switch on the unit and check for leaks during operation.

If leakage occurs, switch off power supply and follow safety instructions for work on live components.

## 9.8 Checking Cable Connections and Electrode Cables

- » Make sure that no cable and plug connections are loose.



**Warning:** Plugs must be pressed down onto electrodes as far as they will go.

Loose cable connections cause excessive contact resistance and overheating of contact surfaces.

- » Check electrode plug isolation, replace plugs as needed.



**Warning:** Replace electrode plugs after removing and reinstalling them several times.

## 9.9 Checking Hoses

Since steam and condensate hoses are also subject to wear they have to be checked regularly.

## 9.10 Checking Operation

Start up the unit and operate for a few minutes at maximum output if possible.

- » Check safety devices.
- » Check hose connections for possible leaks.

## 9.11 Dismantling

After you stop using the steam humidifier, dismantle (demolish or scrap) it by following the installation procedures in reverse order.



**Warning:** Dismantling of the unit is only to be attempted by qualified personnel. Electrical dismantling is only to be attempted by trained professionals.

Note the information provided in Section "Safety Notes" especially the guidelines for disposal.

## 10. EC-Declaration of Conformity

### EG-Konformitätserklärung EC Declaration of Conformity

Hersteller: **HygroMatik GmbH**  
Manufacturer: *HygroMatik GmbH*

Anschrift: Lise-Meitner-Straße 3  
Address: *D-24558 Henstedt-Ulzburg / Germany*

**Produktbezeichnung / Product description:**

**Hy-Line:** HY05, HY08, HY13, HY17, HY23, HY30, HY45, HY60, HY90, HY116

**C-Line:** C01, C02, C06, C10, C17, C22, C30, C45, C58

**MiniSteam:** MS05, MS10

**In den Ausführungen / Type:** Basic, Comfort, Comfort Plus, Dampfbad / *Steam bath (DS)*

**Die bezeichneten Produkte stimmen in der von uns in Verkehr gebrachten Ausführung mit den Vorschriften folgender Europäischer Richtlinien überein:**

*The products described above in the form as delivered are in conformity with the provisions of the following European Directives:*

**2004/108/EG** Richtlinie des Rates zur Angleichung der Rechtsvorschriften der Mitgliedstaaten über die elektromagnetische Verträglichkeit.

*Council Directive on the approximation of the laws of the Member States relating to electromagnetic compatibility.*

**2006/95/EG** Richtlinie des Rates zur Anleitung der Rechtsvorschriften der Mitgliedstaaten betreffend elektrische Betriebsmittel zur Verwendung innerhalb bestimmter Spannungsgrenzen.

*Council Directive on the approximation of the laws of the Member States related to electrical equipment designed for use within certain voltage limits.*

Die Konformität mit den Richtlinien wird nachgewiesen durch die Einhaltung folgender Normen:

*Conformity to the Directives is assured through the application of the following standards:*

Referenznummer:	Ausgabedatum:	Referenznummer:	Ausgabedatum:
<i>Reference number:</i>	<i>Edition:</i>	<i>Reference number:</i>	<i>Edition:</i>
DIN EN 55022	2008-05	DIN EN 60335-1	2007-02
DIN EN 61000-4-2	2001-12	DIN EN 60335-1/A13	2009-05
DIN EN 61000-4-3	2008-06	DIN EN 60335-2-98	2009-04
DIN EN 61000-4-4	2005-07	DIN EN 62233	2008-11
DIN EN 61000-4-5	2007-06	DIN EN 62233 Ber.1	2009-04
DIN EN 61000-4-6	2008-04		

Die Anforderungen des Geräte- und Produktsicherheitsgesetzes (GPSG) §4 Abs. 1 bis 3 werden eingehalten. Eine vom Lieferzustand abweichende Veränderung des Gerätes führt zum Verlust der Konformität. *The requirements of the German Appliance and Product Safety Law (GPSG) paragraph 4 clause 1 to 3 are met. Product modifications after delivery may result in a loss of conformity.*

Henstedt-Ulzburg, den / the 04.10.2011

HygroMatik GmbH



Dirc Menssing  
General Manager



Dr. Andreas Bock  
Technical Manager

Diese Erklärung bescheinigt die Übereinstimmung mit den genannten Richtlinien, ist jedoch keine Zusicherung von Eigenschaften. Die Sicherheitshinweise der mitgelieferten Produktdokumentation sind zu beachten. *This declaration certifies the conformity to the specified directives but contains no assurance of properties. The safety documentation accompanying the product shall be considered in detail.*

## 11. Spare Parts

	HY05	HY13								Articel No.	Description
*	HY08	HY17	HY23	HY30	HY45	HY60	HY90	HY116			
55										E-2124010	Keys for safety, set=2pc.
54										E-2124012	Safety lock incl. 2 keys
											<b>Steam generation</b>
	1									B-3204031	Steam cylinder CY8 compl. with electrodes and hand nuts **
	1									B-2204231	Steam cylinder CY8 DN40 compl. with electrodes and hand nuts **, for SPA applications since 04.2010
		1								B-2204101	Steam cylinder CY17 DN 25 compl. with electrodes and hand nuts **
		1								B-2204103	Steam cylinder CY17 DN 40 compl. with electrodes and hand nuts **, for SPA applications since 04.2010
			1							B-2204111	Steam cylinder CY17 DN 40 compl. with electrodes and hand nuts **
				1		2				B-2204105	Steam cylinder CY30 compl. with electrodes and hand nuts **
					1		2	2		B-2204109	Steam cylinder CY45 compl. with electrodes and hand nuts **
16	1									E-3226005	Top part of steam cylinder CY8 DN 25/12, empty
16	1									E-3226008	Top part of steam cylinder CY8 DN 40/12, empty, , for SPA applications since 04.2010
16		1								E-2206068	Top part of steam cylinder CY17 DN 25/12, empty
16		1								E-2206095	Top part of steam cylinder CY17 DN 40/12, empty, for SPA applications since 04.2010
16			1							E-2206082	Top part of steam cylinder CY17 DN 40/12, empty
16				1		2				E-2206069	Top part of steam cylinder CY30 DN 40/12, empty
16					1		2	2		E-2207001	Top part of steam cylinder CY45 2 x DN 40/12, empty
19	1									B-3216007	Lower part of steam cylinder CY8 compl. with strainer **
19		1	1							B-2206046	Lower part of steam cylinder CY17 compl. with strainer *
19				1		2				B-2206071	Lower part of steam cylinder CY30 compl. with strainer **
19					1		2	2		B-2207002	Lower part of steam cylinder CY45 compl. with strainer **
17	1									E-3216010	O-ring seal for cylinder flange CY8, transparent cylinder
17		1	1							E-2206050	O-ring seal for cylinder flange CY17, transparent cylinder
17				1		2				E-2206051	O-ring seal for cylinder flange CY30, transparent cylinder
17					1		2	2		E-2207011	O-ring seal for cylinder flange CY45, transparent cylinder
35	1									E-3216011	O-ring seal for cylinder base
35		1	1	1	1	2	2	2		E-2204022	O-ring seal for cylinder base
48	1									B-3204019	Electrodes compl. with hand nuts (M6), set=3pc. for CY8
48		1								B-2204081	Electrodes compl. with hand nuts (M8), set=3pc. for CY17
48			1							B-2204083	Electrodes compl. with hand nuts (M8), set=6pc. for CY17 DN40
48				1		2				B-2204095	Electrodes compl. with hand nuts (M8), set=6pc. for CY30 DN40
48					1		2	2		B-2204085	Electrodes compl. with hand nuts (M10), set=6pc. for CY45 DN40
10	1									B-3204027	Sensor electrode compl. with hand nut
10		1	1	1	1	2	2	2		B-2204075	Sensor electrode compl. with hand nut
10	1	1	1	1	1	2	2	2		E-3216025	Plug-in contact with isolating hose for sensorelectrode
4	3									E-3216024	Plug-in contact with isolating hose for steam generating electrodes
4		3	6	6		12				E-2206059	Plug-in contact with isolating hose for steam generating electrodes
4					6		12	12		E-2207016	Plug-in contact with isolating hose for steam generating electrodes

	HY05	HY13								Articel No.	Description
*	HY08	HY17	HY23	HY30	HY45	HY60	HY90	HY116			
18	12	18	18	24	24	48	48	48	E-3216022	Clamp for flange of transparent cylinder	
37	1								E-3220000	Cylinder base DN20/25/15/12	
37		1	1	1	1	2	2	2	E-2206086	Cylinder base DN40/25/15/12	
	1								B-3216023	Mounting set for Cylinder base	
		1	1	1	1	2	2	2	B-2214023	Mounting set for Cylinder base	
12	1	1	1	1	1	2	2	2	E-2204035	Condensate cap DN12	
1	1								E-3221002	Adapter for steam hose DN25, CY8	
1	1								E-3221008	Adapter for steam hose DN40, CY8, for SPA applications since 04.2010	
1		1							E-2209000	Adapter for steam hose DN25, CY17	
1		1							E-2209004	Adapter for steam hose DN40, CY17, for SPA applications since 04.2010	
1			1						E-2209004	Adapter for steam hose DN40, CY17	
1				1		2			E-2209006	Adapter for steam hose DN40, CY 30	
1					2		4	4	E-2209008	Adapter for steam hose DN40, CY 45	
1		1							E-2209014	Adapter steam outlet DN40/25	
2	1	1							E-3221004	Clip for adapter DN25	
2			1	1	2	2	2	2	E-2209002	Clip for adapter DN40	
3	1	1							E-3221006	O-ring for adapter DN25	
3	1	1							E-2204022	O-ring for adapter DN40, for SPA applications since 04.2010	
3			1	1	2	2	2	2	E-2204022	O-ring for adapter DN40	
	1								B-3216073	O-ring set CY8 (Pos. 3, 17, 35)	
	1								B-3216099	O-ring set CY8 DN40 (Pos. 3, 17, 35), for SPA applications since 04.2010	
		1							B-2207021	O-ring set CY17 DN25 (Pos. 3, 17, 35)	
		1							B-2207023	O-ring set CY17 DN40 (Pos. 3, 17, 35), for SPA applications since 04.2010	
			1						B-2207023	O-ring set CY17 DN40 (Pos. 3, 17, 35)	
				1		2			B-2207025	O-ring set CY30 (Pos. 3, 17, 35)	
					1		2	2	B-2207027	O-ring set CY45 (Pos. 3, 17, 35)	
	1								B-3216079	maintenance set for steam cylinder CY8, DN25 ***	
	1								B-2207081	maintenance set for steam cylinder CY8, DN40 ***, for SPA applications since 04.2010	
		1							B-2207029	maintenance set for steam cylinder CY17 DN25 ***	
		1							B-2207045	maintenance set for steam cylinder CY17 DN40 ***, for SPA applications since 04.2010	
			1						B-2207031	maintenance set for steam cylinder CY17 DN40 ***	
				1		2			B-2207033	maintenance set for steam cylinder CY30 ***	
					1		2	2	B-2207035	maintenance set for steam cylinder CY45 ***	
										<b>Water feed</b>	
21	0,9	1,6	1,6	1,6	1,9	1,6	1,9	1,9	E-2604002	Connecting hose solenoid valve - cylinder base, per m	
25	1								B-2304021	Solenoid valve, servo controlled, straight type, 0,2-10bar, 2,5 l/min.	
25		1	1	1	1	2	2	2	B-2304023	Solenoid valve, servo controlled, straight type, 0,2-10bar, 3,5 l/min.	
56	1	1	1	1	1	2	2	2	B-2304031	Hose for water connection, 3/4" cap nuts on both sides, seal included	
	1								E-3320400	Flow rate controller 2,5 l/min	
		1	1	1	1	2	2	2	E-2321100	Flow rate controller 3,5l/min	
	1								B-2304055	Double solenoid valve for Super flush applications, 2,5l/min	
		1	1	1	1	2	2	2	B-2304057	Double solenoid valve for Super flush applications, 3,5l/min	
29	1	1	1	1	1	2	2	2	E-2304024	Fine filter in the inlet fitting of solenoid valve	
38	0,4	0,7	0,7	0,7	0,8	0,7	0,8	0,8	E-2604004	Hose for manual water drain, per m	
20	1	1	1	1	1	1	1	1	E-2604066	Stopper, conical, lock for hose	
	1	1	1	1	1	2	2	2	E-2305002	seal for hose for water connection (B-2304031)	
22	4	4	4	4	4	8	8	8	E-2304015	Hose clamp 10-16mm	
									E-2604002	Connecting hose solenoid valve - bush for earthing	
24	0,07	0,07	0,07	0,07	0,07	0,07	0,07	0,07		Connecting hose solenoid valve - bush for earthing	
23	1	1	1	1	1	2	2	2	E-2304080	Bush for earthing	

	HY05	HY13								Articel No.	Description
*	HY08	HY17	HY23	HY30	HY45	HY60	HY90	HY116			
											<b>Water drain</b>
	1									B-3401017	Drain-hose-system (Pos. 6, 14, 15, 30, 31)
		1	1							B-3401019	Drain-hose-system (Pos. 6, 14, 15, 30, 31)
				1		2				B-3401013	Drain-hose-system (Pos. 6, 14, 15, 30, 31)
					1		2	2		B-3401021	Drain-hose-system (Pos. 6, 14, 15, 30, 31)
31	1	1	1	1	1	2	2	2		E-3220005	O-ring for pump-adapter
31	1	1	1	1	1	2	2	2		E-3220005	O-ring for cylinder base -pump
33		1	1	1	1	1	1	1		E-2404024	O-ring for drain pump (cover-motor)
32	1	1	1	1	1	2	2	2		B-2404027	Drain pump without mounting set
	1	1	1	1	1	2	2	2		B-2424014	Mounting set for drain pump (pos. 42-44)
6	1	1	1	1	1	2	2	2		E-2425004	Elbow with vent pipe
57	1	1	1	1	1	2	2	2		E-2420423	Drain hose 1 1/4"
39	1	1	1	1	1	2	2	2		E-8501064	Hose clamp 12-20mm
38	0,5	0,7	0,7	0,7	0,8	2x0,7	2x0,8	0,8		E-2604004	Manual drain hose
											<b>Control</b>
											<b>universal</b>
	1									E-2501005	Main contactor 16 A, 230 V
		1								B-2507041	Main contactor 20 A, 230 V
			1	1		2				B-2507061	Main contactor 35 A, 230 V
							2			B-2507071	Main contactor 50 A, 230 V
					1			2		B-2507081	Main contactor 65 A, 230 V
	1	1	1	1	1	2	2	2		E-2505206	Control fuse (fast acting) 1,6 A, 5x20 mm
4	1									B-3526019	Connecting cables for electrodes with plug-in contact, set=3pc
4		1								B-2524201	Connecting cables for electrodes with plug-in contact, set=3pc
4			1							B-2524205	Connecting cables for electrodes with plug-in contact, set=6pc
4				1						B-2524209	Connecting cables for electrodes with plug-in contact, set=6pc
4					1					B-2524213	Connecting cables for electrodes with plug-in contact, set=6pc
4						2				B-2524217	Connecting cables for electrodes with plug, set=6pc
4							2	2		B-2524225	Connecting cables for electrodes with plug, set=6pc
8	1	1	1							B-2525051	Connecting cable sensor electrode with plug
8					1	1	1			B-2525053	Connecting cable sensor electrode with plug (HY 60 = for right cylinder)
8							1			B-2525057	Connecting cable sensor electrode with plug (HY60 = for left cylinder)
8								1	1	B-2525055	Connecting cable sensor electrode with plug (HY90/HY116 = for right cylinder)
8								1	1	B-2525059	Connecting cable sensor electrode with plug (HY90/HY116 = for left cylinder)
											<b>Steam generation with electrical supply higher than 500V</b>
		1	1							E-2206054	O-ring CY17, silicone, for cylinder flange
				1		2				E-2206056	O-ring CY30, silicone, for cylinder flange
					1		2	2		E-2207014	O-ring CY45, silicone, for cylinder flange
		1								B-2208007	Cylinder star CY17/3
			1							B-2208013	Cylinder star CY17/6
				1		2				B-2208009	Cylinder star CY 30
					1		2	2		B-2208011	Cylinder star CY 45
		2,5	5	8		16				E-9000110	Cable H07V-K2,5 [m]
		3	6	6		12				E-2206059	Plug-in contact for electrode 35A
					8		16	16		E-9000132	Cable H07V-K6,0 [m]
					6		12	12		E-2207016	Plug-in contact for electrode 63A



	HY05	HY13								Articel No.	Description
*	HY08	HY17	HY23	HY30	HY45	HY60	HY90	HY116			
											<b>Control, electrical supply higher than 500V</b>
		1	1	1	1	2	2	2	E-2504158	Transformer 690 V/230V, 25VA	
		1	1	1	1	2			E-2504168	Transformer 480 V-500V/230V	
		1	1	1	1	2	2	2	E-2504160	Transformer 600 V/230V	
		1	1	1	1	2	2	2	E-2504166	Transformer 690 V/230V, 130VA	
		1	1	1	1	2	2	2	E-2590102	Line safety switch, 1 A	
											<b>Control, electrical supply between 416V and 480V</b>
					1		1	1	E-2507024	Main Contactor 60A, 230V/690V	
		1	1	1		2			E-2507022	Main Contactor 40A, 230V/690V	
		1	1						E-2507018	Main Contactor 25A, 230V/690V	
		1	1	1	1	2	2	2	E-2504220	Transformer 208V-460V/230V	
		1	1	1	1	2	2	2	E-2504168	Transformer 480 V/230V	
											<b>Control, electrical supply below 230V</b>
					1				E-2504092	Main contactor 100 A, 230 V	
			1	1		2			B-2507081	Main contactor 65 A, 230 V	
		1							B-2507061	Main contactor 35 A, 230 V	
	1								B-2507041	Main contactor 20 A, 230 V	
				1					B-2524015	Cable for electrode 35A/6mm <sup>2</sup>	
											<b>Basic Control</b>
	1	1	1	1	1	2	2	2	B-2526201	Basic Mainboard	
51	1	1	1	1	1	2	2	2	E-2502412	Control switch, double pole	
	1	1	1	1	1	2	2	2	B-2120901	Mounting plate for Basic with foil	
											<b>Comfort Control</b>
	1	1	1	1	1	2	2	2	B-2526201	Basic Mainboard	
51	1	1	1	1	1	2	2	2	E-2502412	Control switch, double pole	
	1	1	1	1	1	1	1	1	B-2120903	Mounting plate (standard) with foil	
	1	1	1	1	1	1	1	1	B-2526401	Display (standard) with mounting plate and foil	
						1	1	1	B-2120901	Mounting plate and foil (Basic)	
											<b>Comfort Plus Control</b>
	1	1	1	1	1	2	2	2	B-2526201	Basic Mainboard	
51	1	1	1	1	1	2	2	2	E-2502412	Control switch, double pole	
	1	1	1	1	1	1	1	1	B-2120905	Mounting plate (advanced) with foil	
	1	1	1	1	1	1	1	1	B-2526403	Display (advanced) with mounting plate and foil	
						1	1	1	B-2120901	Mounting plate and foil (Basic)	
											<b>DS Control</b>
	1	1	1	1	1				B-2526211	DS-Basic Mainboard	
51	1	1	1	1	1				E-2502412	Control switch, double pole switch, middle position "0"	
	x	x	x	x	x				B-2526401	Display (Comfort), grey, until Dec. 2010	
	x	x	x	x	x				B-2526403	Display (Comfort Plus), grey, until Dec. 2010	
	x	x	x	x	x				B-2526445	Display (Comfort), yellow, since Jan. 2010	
	x	x	x	x	x				B-2526447	Display (Comfort), grey, since Jan. 2010	

	HY05	HY13								Articel No.	Description
*	HY08	HY17	HY23	HY30	HY45	HY60	HY90	HY116			
	x	x	x	x	x					E-0605228	Temperature sensor TF104
	x	x	x	x	x					B-2505207	Holder for temperature sensor TF104 incl. mounting set
	x	x	x	x	x					E-2505206	Fuse for light, fan, essence injector 1.6A, 5x20mm
	x	x	x	x	x					E-2504039	Fuse for transformer 5A, 5x20mm
	x	x	x	x	x					E-2504200	Transformer 230/24V/130VA
											<b>Essence injection</b>
	x	x	x	x	x					B-2604091	Peristaltic pump DSP9911; 230V/50Hz; 50ml/min
	x	x	x	x	x					B-2604083	Peristaltic pump DSP9911; 24V/50Hz; 50ml/min
	x	x	x	x	x					E-2604072	Hose for peristaltic pump DSP9431 (until 06/2002)
	x	x	x	x	x					E-2604074	Hose for peristaltic pump DSP9111 (since 07/2002)
	x	x	x	x	x					E-2604076	hose connector for silicon hoses, 6mm
	x	x	x	x	x					E-2604070	Hose for essence injection; silicon 6x1,5
	x	x	x	x	x					B-2604067	T-piece for essence injection (DN25)
	x	x	x	x	x					B-2604069	T-piece for essence injection (DN40)
											<b>Accessoires</b>
	x	x								E-2604012	Steam hose DN 25, per m
	x	x								E-2604013	Steam hose DN 40, per m, for SPA application since 04.2010
										E-2604013	Steam hose DN 40, per m
	x	x	x	x	x	x	x	x		E-2604002	Condensate hose DN 12, per m
	x	x								E-2404004	Steam hose clamp DN 25
	x	x								E-2604016	Steam hose clamp DN 40, for SPA application since 04.2010
			x	x	x	x	x	x		E-2604016	Steam hose clamp DN 40
	x	x	x	x	x	x	x	x		E-2304015	Condensate hose clamp
	x	x	x	x	x	x	x	x		E-2604049	double check valve
	x	x								B-2604025	Steam solenoid valve 0-0,4 bar, cpl. for steam hose DN 25
	x	x								B-2604040	Steam solenoid valve 0-0.4 bar, cpl. for steam hose DN 40, for SPA application since 04.2010
			x	x	x	x	x	x		B-2604040	Steam solenoid valve 0-0.4 bar, cpl. for steam hose DN 40
	x	x								E-2604042	Steam connector, T-piece DN 25, stainless steel
	x	x								E-2604023	Steam connector, T-piece DN 40, stainless steel, for SPA application since 04.2010
			x	x	x	x	x	x		E-2604023	Steam connector, T-piece DN 40, stainless steel
	x	x	x	x	x	x	x	x		E-2604021	Connectors for condensate T-piece DN 12
	x									B-2208005	Cylinder star, complete
		x								B-2208007	Cylinder star, complete
			x							B-2208013	Cylinder star, complete
				x		x				B-2208009	Cylinder star, complete
					x		x	x		B-2208011	Cylinder star, complete
	x									B-2304063	Super flush, upgrade kit
		x	x	x	x	x	x	x		B-2304065	Super flush, upgrade kit
	x	x	x	x	x	x	x	x		B-2304079	Nozzle for Super Flush
	x	x	x	x	x	x	x	x		B-2304031	Water connection hose, flexible, 0.6 m 3/4", with connector

**If you order any spare parts, specify type and serial number of the unit, please.**

\* see Exploded View

\*\* If the Super Flush System is installed, consider to order also a new nozzle (B-2304079), please.

The nozzle will be already installed in the lower part of steam cylinder.

\*\*\* Maintenance set consists of: electrodes (without hand nuts), O-ring for steam hose adapter, O-ring for cylinder flange, O-ring cylinder base, O-ring sensor electrode, 3 clamps (Pos.18) for cylinder flange.



**12. Fax Form - Order for spare parts**



Lise-Meitner-Str. 3  
24558 Henstedt-Ulzburg  
Tel. +4904193/895-0

**Fax Form**

Please copy, fill in and fax to  
Fax.No. **+49(0)4193/895-31**

# Order of spare parts

**unit type \*** \_\_\_\_\_ **serial no.\*** \_\_\_\_\_

commission: \_\_\_\_\_ order no.: \_\_\_\_\_

quantity	article	article no.

date of delivery \_\_\_\_\_ forwarder \_\_\_\_\_ shipment by \_\_\_\_\_

delivery address (if different  
from invoice address)

\_\_\_\_\_

\_\_\_\_\_

\_\_\_\_\_

\_\_\_\_\_

company stamp (delivery adress)

date/signature

\* Order can only be processed if unit type and unit serial no. are filled in.

### 13. Technical Specification

Technical Specifications Steam Humidifier HyLine					
Type	HY05	HY08	HY13	HY17	HY23
Steam output [kg/h]	5	8	13	17	23
Power supply *	400V/3~/N/50-60 Hz				
Power Usage [kW]	3,8	6,0	9,8	12,8	17,3
Input [A]	5,4	8,7	14,1	18,4	24,9
Circuit Protection [A]***	3x6	3x10	3x16	3x20	3x35
Control	Basic, Comfort, Comfort Plus				
Control voltage	230 V				
Steam hose connection [mm]	1x25	1x25	1x25	1x25	1x40
Condensate hose connection [mm]	1x12	1x12	1x12	1x12	1x12
empty weight [kg]	13	13	20	20	22
operating weight [kg]	19	19	38	38	40
dimensions	height [mm]	481	481	654	654
	width [mm]	449	449	520	520
	depth [mm]	216	216	284	284
Water Installation	100 x 10 <sup>3</sup> to 100 x 10 <sup>4</sup> pascal with 3/4" connection for external thread				
fan unit**	VG08	VG08	VG17	VG17	VG30
air flow capacity [m <sup>3</sup> /h]	185	185	185	185	350
* Other voltages on request.					
** Not included with delivery.					
*** Multiply power input by 1.3 after full blow-down. Note overload capacity of automatic breakers. If necessary, select the next higher rating.					

Technical Specifications Steam Humidifier HyLine					
Type	HY30	HY45	HY60	HY90	HY116
Steam output [kg/h]	30	45	60	90	116
Power supply *	400V/3/N/50-60 Hz				
Power Usage [kW]	22,5	33,8	2x22,5	2x33,8	2x43,5
Input [A]	32,5	48,8	2x32,5	2x48,8	2x62,8
Circuit Protection [A]***	3x35	3x63	6x35	6x63	6x63
Control	Basic, Comfort, Comfort Plus				
Control voltage	230 V				
Steam hose connection [mm]	1x40	2x40	2x40	4x40	4x40
Condensate hose connection [mm]	1x12	2x12	2x12	4x12	4x12
empty weight [kg]	28	39	47	70	70
operating weight [kg]	55	85	101	162	162
dimensions	height [mm]	710	788	712	792
	width [mm]	560	653	927	1061
	depth [mm]	327	405	336	404
Water Installation	100 x 10 <sup>3</sup> to 100 x 10 <sup>4</sup> with 3/4" connection for external thread				
fan unit**	VG30	2xVG30	2xVG30	3xVG30	4xVG30
airflow capacity [m <sup>3</sup> /h]**	350	2x350	2x350	3x350	4x350
* Other voltages on request.					
** Not included with delivery.					
*** Multiply power input by 1.3 after full blow-down. Note overload capacity of automatic breakers. If necessary, select the next higher rating.					

## Technical Specification

<b>Technical Specifications Steam Humidifier HyLine for SPA</b>						
<b>HY05..-DS - HY23..-DS</b>						
Type	HY05	HY08	HY13	HY17	HY23	
Steam output [kg/h]	5	8	13	17	23	
Power supply *	400V/3~/N/50-60 Hz					
Power Usage [kW]	3,8	6,0	9,8	12,8	17,3	
Input [A]	5,4	8,7	14,1	18,4	24,9	
Circuit Protection [A]***	3x6	3x10	3x16	3x20	3x35	
Control	Basic-DS, Comfort-DS, Comfort Plus-DS					
Control voltage	230 V					
Steam hose connection [mm]	1x40	1x40	1x40	1x40	1x40	
Condensate hose connection [mm]	1x12	1x12	1x12	1x12	1x12	
empty weight [kg]	13	13	20	20	22	
operating weight [kg]	19	19	38	38	40	
dimensions	height [mm]	481	481	654	654	654
	width [mm]	449	449	520	520	520
	depth [mm]	216	216	284	284	284
Water Installation	100 x 10 <sup>3</sup> to 100 x 10 <sup>4</sup> pascal with 3/4" connection for external thread					
* Other voltages on request. ** Not included with delivery. *** Multiply power input by 1.3 after full blow-down. Note overload capacity of automatic breakers. If necessary, select the next higher rating.						

<b>Technical Specifications Steam Humidifier HyLine for SPA</b>						
<b>HY30..-DS - HY116..DS</b>						
Type	HY30	HY45	HY60	HY90	HY116	
Steam output [kg/h]	30	45	60	90	116	
Power supply *	400V/3~/N/50-60 Hz					
Power Usage [kW]	22,5	33,8	2x22,5	2x33,8	2x43,5	
Input [A]	32,5	48,8	2x32,5	2x48,8	2x62,8	
Circuit Protection [A]***	3x35	3x63	6x35	6x63	6x63	
Control	Basic-DS, Comfort-DS, Comfort Plus-DS					
Control voltage	230 V					
Steam hose connection [mm]	1x40	2x40	2x40	4x40	4x40	
Condensate hose connection [mm]	1x12	2x12	2x12	4x12	4x12	
empty weight [kg]	28	39	47	70	70	
operating weight [kg]	55	85	101	162	162	
dimensions	height [mm]	710	788	712	792	792
	width [mm]	560	653	927	1061	1061
	depth [mm]	327	405	336	404	404
Water Installation	100 x 10 <sup>3</sup> to 100 x 10 <sup>4</sup> with 3/4" connection for external thread					
* Other voltages on request. ** Not included with delivery. *** Multiply power input by 1.3 after full blow-down. Note overload capacity of automatic breakers. If necessary, select the next higher rating.						

## 14. Exploded View

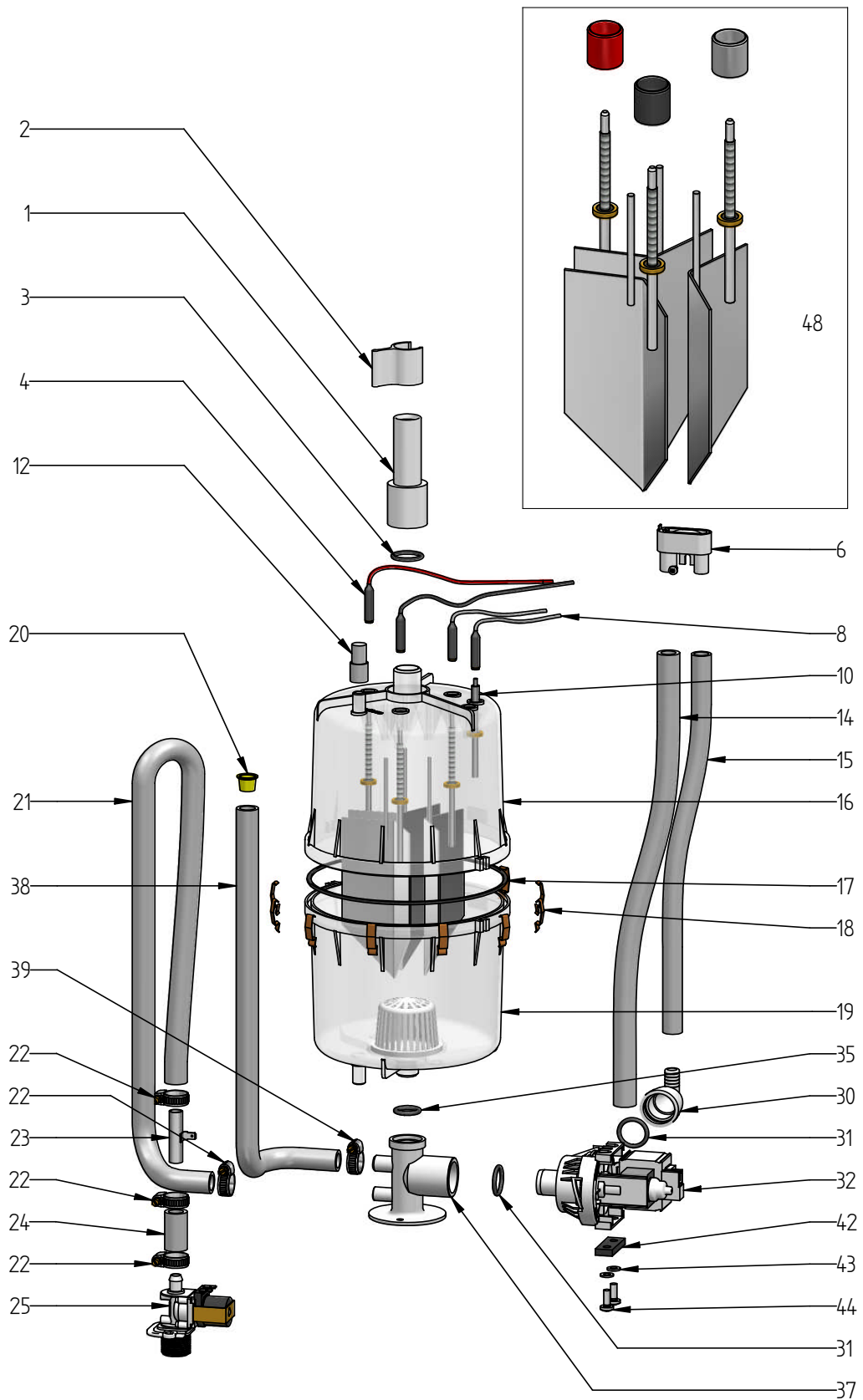

### 15. View of housing

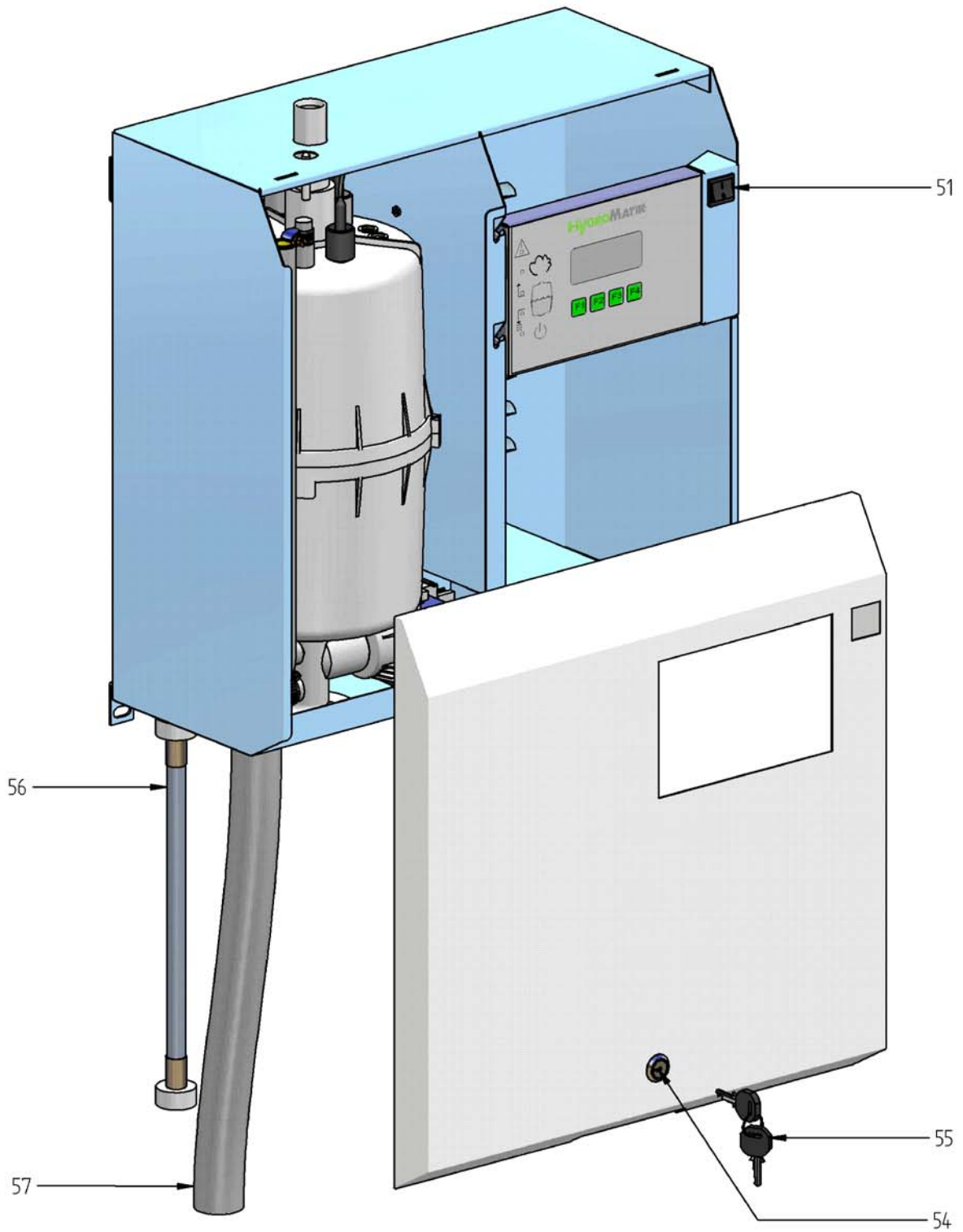



# HyGROMATIK®

Lise-Meitner-Str.3 • D-24558 Henstedt-Ulzburg  
Phone +49(0)4193/ 895-0 • Fax -33  
eMail [hy@hygromatik.de](mailto:hy@hygromatik.de) • [www.hygromatik.com](http://www.hygromatik.com)  
A member of the **spirax/sarco** Group